



WAM®



3

SPARE PARTS

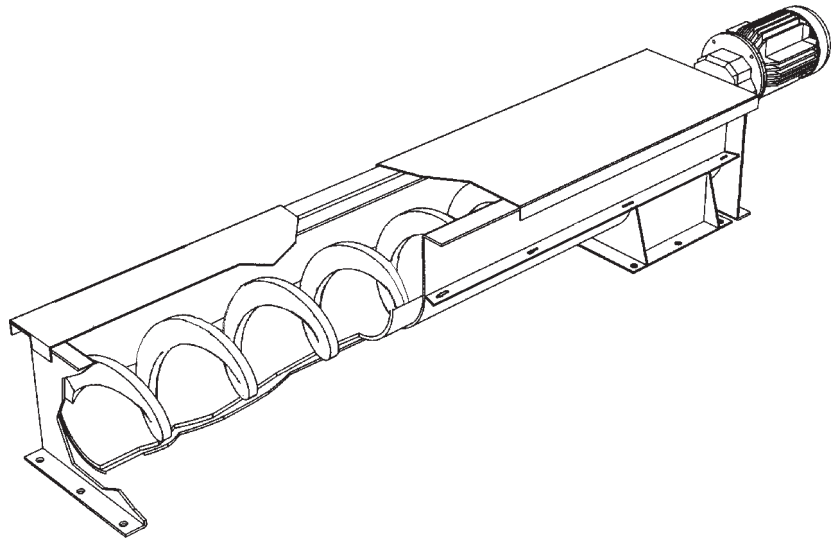

SSC

- **SHAFTLESS SPIRAL CONVEYORS**
SPARE PARTS CATALOGUE
- **SPIRALFÖRDERER**
ERSATZTEILKATALOG
- **TRANSPORTEURS A VIS SANS ÂME**
PIECES DE RECHANGE
- **TRASPORTATORI A COCLEA SENZA TUBO INTERNO**
PEZZI DI RICAMBIO

All rights reserved © WAMGROUP

CATALOGUE No.		WA.01050. R	CREATION DATE
ISSUE	CIRCULATION	DATE OF LATEST UPDATE	
A4	100	04.01	03 - 2000



All the products described in this catalogue are manufactured according to **WAM® S.p.A. Quality System procedures.**

The Company's Quality System, certified in July 1994 according to International Standards **UNI EN ISO 9002-94** and extended to **UNI EN ISO 9001-2000** in October, 2002, ensures that the entire production process, starting from the processing of the order to the technical service after delivery, is carried out in a controlled manner that guarantees the quality standard of the product.

*Alle in diesem Katalog beschriebenen Erzeugnisse werden in Konformität mit dem **Qualitätssystem der WAM® S.p.A. hergestellt.***

*Das im Juli 1994 zertifizierte Qualitätssystem entspricht der Norm **UNI EN ISO 9002-94** (im Oktober 2002 auf **UNI EN ISO 9001-2000** erweitert) und gewährleistet dem Kunden eine strenge Qualitätskontrolle in jeder Phase des Produktionsprozesses bis hin zum Kundendienst nach Auslieferung der Ware.*

Tous les produits décrits dans ce catalogue ont été réalisés selon les modalités opérationnelles définies **Système de Qualité de WAM® S.p.A.**

Le système de Qualité de l'entreprise, certifié au mois de juillet 1994 en conformité aux Normes Internationales **UNI EN ISO 9002-94** et successivement étendu à **UNI EN ISO 9001-2000** au mois de octobre 2002, est en mesure d'assurer que le procédé entier de production, à partir de la formulation de la commande jusqu'au service technique après la livraison, soit effectué de manière contrôlée et appropriée afin de garantir le standard de qualité du produit.

*Tutti i prodotti descritti in questo catalogo sono stati realizzati secondo modalità operative definite **Sistema Qualità di WAM® S.p.A.***

*Il Sistema Qualità aziendale, certificato dal luglio 1994 in conformità alle Normative Internazionali **UNI EN ISO 9002-94** e successivamente esteso alle Normative Internazionali **UNI EN ISO 9001-2000** nell'ottobre 2002, è in grado di assicurare che l'intero processo produttivo, dalla formulazione dell'ordine fino all'assistenza tecnica successiva alla consegna, venga effettuato in modo controllato ed adeguato a garantire lo standard qualitativo del prodotto.*



Possible deviations due to modifications and/or manufacturing tolerances are reserved.

Abweichungen infolge Änderungen und/oder aufgrund von Fertigungstoleranzen sind vorbehalten.

Nous nous réservons des écarts éventuels dus des modifications et/ou des tolérances d'usage.

Ci riserviamo eventuali scostamenti dovuti a modifiche e/o tolleranze di lavorazione.

1	TECHNICAL CATALOGUE		
	CODE INDEX.....	TECHNISCHER KATALOG	T . 8
	INTRODUCTION.....	CODES.....	“ . 9
	STANDARD SUPPLY.....	EINFÜHRUNG.....	“ . 10
	OPTIONS AND ACCESSORIES.....	STANDARD-LIEFERUMFANG.....	“ . 11
	OVERALL DIMENSION.....	VARIANTEN UND ZUBEHÖR.....	“ . 12
	MECHANICAL COMPONENTS.....	EINBAUMASSE.....	“ . 13
	FABRICATED COMPONENTS.....	MECHANISCHE KOMPONENTEN.....	“ . 14
	SSC1 SURFACE FINISHES.....	STAHLBAUTEILE.....	“ . 15
	COLOURS SSC1.....	OBERLÄCHENFINISH SSC1.....	“ . 16
	SCREW FINISH.....	FARB TÖNE SSC1.....	“ . 17
	COLOURS SSC 2X.....	SCHECKENFINISH.....	“ . 18
	MODULAR CODE KEY.....	FARB TÖNE SSC 2X.....	“ . 19
	INQUIRY FORM.....	SUCHCODESCHLÜSSEL.....	“ . 20
	COMPOUND TROUGH.....	ANFRAGEFORMULAR.....	“ . 21
	DRIVE END PLATE.....	ZUSAMMENGETZTER TROG.....	“ . 22 → . 24
	BLANK END PLATE.....	ANTRIEBSSEITIGER ENDSCHILD.....	“ . 25 → . 28
	SPIRAL -MILD STEEL, ST ST AISI 304L AND ST.ST.316L.....	BLIND ENDSCHILD.....	“ . 29
	XAZ TYPE COUPLING.....	SPIRALWENDEL -STAHL, EDELSTHAL 1.4306, UND EDELSTHAL 1.4404.....	“ . 30
	LINER MADE OF HDPE.....	WELLENVERBINDUNG XAZ.....	“ . 31
	XBY -TYPE OUTLET.....	TROGAUSKLEIDUNG AUS HDPE.....	“ . 32
	TROUGH COVER.....	AUSLAUF XBY.....	“ . 33
	COVER LOCK.....	TROGABDECKUNG.....	“ . 34
	XSV TYPE END BEARING ASSEMBLIES TYPE.....	ABDECKUNGSVERSCHLUSS.....	“ . 35
	SHAFT SEALING TYPE - XUC.....	ENDLAGEREINHEIT XSV.....	“ . 36
	MOTOR MT.....	WELLENABDICHTUNG TYP XUC.....	“ . 37
	OPTIONS - GEAR REDUCER - TYPE S 21-23 -25 - 27.....	MOTOR MT.....	“ . 38
	OPTIONS - HOLLOW SHAFT GEAR MOTOR.....	VARIANTEN - GETRIEBE TYP S 21-23 - 25 - 27.....	“ . 39
	OPTIONS - RA 70 -TYPE GEAR REDUCER.....	VARIANTEN - HOHLWELLENGETRIEBEMOTOR.....	“ . 40
	OPTIONS - RA 85 - 100 - 150 -TYPE GEAR REDUCER.....	OPTIONEN - GETRIEBE TYP RA70.....	“ . 41
	OPTIONS - P23 - 25 - 27 -TYPE GEAR REDUCER.....	OPTIONEN - GETRIEBE TYP RA85 - 100 - 150.....	“ . 42
	OPTIONS - FZAF 88 -TYPE GEAR REDUCER.....	OPTIONEN - GETRIEBE P 23-25-27.....	“ . 43
	OPTIONS - FZAF 108 -TYPE GEAR REDUCER.....	OPTIONEN - GETRIEBE FZAF 88.....	“ . 44
	OPTIONS - SEAL GLAND FLANGE FOR RA.....	OPTIONEN - GETRIEBE FZAF 108.....	“ . 45
	OPTIONS - BELT TRANSMISSION (“R -S”-TYPE GEAR REDUCER).....	OPTIONEN - DICHTUNGSTRAGENDER FLANSCH FÜR RA.....	“ . 46
	OPTIONS - CHAIN TRANSMISSION (“S”-TYPE GEAR REDUCER).....	VARIANTEN - RIEMENTRIEB (GETRIEBE TYP “R -S”).....	“ . 47
	OPTIONS - COUPLING TRANSMISSION (“S”-TYPE GEAR REDUCER).....	VARIANTEN - KETTENTRIEB (GETRIEBE TYP “S”).....	“ . 48
	OPTIONS - LINER MADE OF UHMWPE.....	VARIANTEN - KUPPLUNG (GETRIEBE TYP “S”).....	“ . 49 → . 50
	OPTIONS - EXTRA THICK TWO-COLOUR UHMWPE LINER.....	OPTIONEN - TROGAUSKLEIDUNG AUS UHMWPE.....	“ . 51 → . 52
	OPTIONS - XJF -TYPE BOLTED TROUGH BOTTOM PLATE.....	OPTIONEN - EXTRA - STARKE UHMWPE ZWEIFARBIGE TROGAUSKLEIDUNG.....	“ . 53
	ACCESSORIES - XJB - TYPE WELDED SLIDE BARS.....	OPTIONEN - GESCHRAUBTE TROGAUSKLEIDUNG TYP XJF.....	“ . 54
	ACCESSORIES - XJB - TYPE BOLTED SLIDE BARS.....	ZUBEHÖR - GESCHWEISSTE SCHLEISSLEISTEN TYP XJB.....	“ . 55
	OPTIONS - XBQ TYPE INLET.....	ZUBEHÖR - GESCHRAUBTE SCHLEISSLEISTEN TYP XJB.....	“ . 56
	OPTIONS - XBV TYPE INLET.....	OPTIONEN - EINLAUF TYP XBQ.....	“ . 57
	OPTIONS - XBR TYPE INLET.....	OPTIONEN - EINLAUF TYP XBV.....	“ . 58
	ACCESSORIES - CYLINDRICAL INLET XBC.....	OPTIONEN - EINLAUF TYP XBR.....	“ . 59
	OPTIONS - CYLINDRICAL OUTLET XBC.....	ZUBEHÖR - ZYLINDRISCHER EINLAUF XBC.....	“ . 60
	OPTIONS - XBW -TYPE FLUSH OUTLET.....	OPTIONEN - ZYLINDRISCHER AUSLAUF XBC.....	“ . 61
	ACCESSORIES - XBQ -TYPE ADDITIONAL OUTLET.....	OPTIONEN - FRONTALAUSLAUF XBW.....	“ . 62
	OPTIONS - BUILT-IN TROUGH.....	ZUBEHÖR - ZUSÄTZLICHER AUSLAUF TYP XBQ.....	“ . 63
	OPTIONS - ZBAS - TYPE FLUSH OUTLET.....	OPTIONEN - INTEGRALTROG.....	“ . 64
	OPTIONS - ZBSR WELDED OUTLET SPOUT.....	OPTIONEN - FRONTALAUSLAUF TYP ZBAS.....	“ . 65
	OPTIONS - ZBQ TYPE INLET.....	OPTIONEN - GESCHWEISSTER AUSLAUFSTUTZEN ZBSR.....	“ . 66
	OPTIONS - ZBR TYPE INLET.....	OPTIONEN - EINLAUF TYP ZBQ.....	“ . 67
	OPTIONS - ZBI TYPE INLET.....	OPTIONEN - EINLAUF TYP ZBR.....	“ . 68
	ACCESSORIES - XBV -TYPE ADDITIONAL OUTLET.....	OPTIONEN - EINLAUF TYP ZBI.....	“ . 69
	ACCESSORIES - XBR -TYPE ADDITIONAL OUTLET.....	ZUBEHÖR - ZUSÄTZLICHER AUSLAUF TYP XBV.....	“ . 70
	ACCESSORIES - DRAINAGE SET.....	ZUBEHÖR - ZUSÄTZLICHER AUSLAUF TYP XBR.....	“ . 71
	ACCESSORIES - HIGH SIDE TROUGH XZS.....	ZUBEHÖR - DRAINAGEEINHEIT.....	“ . 72
	ACCESSORIES - XPR HIGH END PLATE.....	ZUBEHÖR - ERHÖHTE TROG XZS.....	“ . 73
	ACCESSORIES - XFBA - TYPE OVERFLOW HATCH FLAP.....	ZUBEHÖR - ERHÖHTE ENDSCHILD XPR.....	“ . 74
	ACCESSORIES - XKX - TYPE FINGER MESH BENEATH HATCH FLAP.....	ZUBEHÖR - ÜBERLAUFKLAPPE TYP XFBA.....	“ . 75
	ACCESSORIES - XJQ - TYPE COVER SUPPORT BRACKET.....	ZUBEHÖR - SCHUTZGITTER TYP XKX UNTER ÜBERLAUFKLAPPE.....	“ . 76
	OPTIONS - SPIRAL GUIDING SIDE CHANNEL XZG.....	ZUBEHÖR - ABDECKUNGS-AUFLAGEBÜGEL TYP XJQ.....	“ . 77
	OPTIONS - FWB - TYPE FLUSH OUTLET.....	VARIANTEN - WENDELFÜHRUNG XZG.....	“ . 78
	OPTIONS - DOUBLE FLIGHTING - MILD STEEL AND ST.ST.304L.....	OPTIONEN - FRONTALAUSLAUF FWB.....	“ . 79
	ACCESSORIES - TROUGH FOOT TYPE XJS.....	VARIANTEN - DOPPELWENDEL - STAHL UND EDELSTHAL 1.4306.....	“ . 80
	ACCESSORIES - XKM - TYPE SCREW LAMP.....	ZUBEHÖR - TROGFUSS TYP XJS.....	“ . 81
	ACCESSORIES - PIPE COUPLING AND PLUG.....	ZUBEHÖR - SCHRAUBZWINGENVERSCHL. XKM.....	“ . 82
	ACCESSORIES - XKU -TYPE SPRAYING NOZZLE.....	ZUBEHÖR - GEWINDEMUFFE MIT BLINDSTOPFEN.....	“ . 83
	ACCESSORIES - ANGULAR BREKETS.....	ZUBEHÖR - SPRÜHDÜSE TYP XKU.....	“ . 84
	ACCESSORIES - TYPE RA CASING MTR.....	ZUBEHÖR - WINKELBÜGEL.....	“ . 85
	ACCESSORIES - ADJUSTABLE SUPPORT FEED 1000 - 500 mm.....	ZUBEHÖR - GEHAUSE MTR TYP RA.....	“ . 86
	ACCESSORIES - WATER DRAINAGE UNIT.....	ZUBEHÖR - VERSTELLBARE FUSSE 1000 - 500 mm.....	“ . 87
	ACCESSORIES - FLIGHT PRESSOR.....	ZUBEHÖR - WASSERAUSLAUFEINHEIT.....	“ . 88
	ACCESSORIES - SIDE COUPLING.....	ZUBEHÖR - WENDELKÄFIG.....	“ . 89
	WEIGHT.....	ZUBEHÖR - SEITENEINLEITUNG.....	“ . 90
	TROUGH CONFIGURATION Ø 150 - 200 - 250.....	GEWICHTE.....	“ . 91
	TROUGH CONFIGURATION Ø 300 - 350 - 400 - 500 - 600.....	TROGKONFIGURATION Ø 150 - 200 - 250.....	“ . 92
	SHIPPING DATA Ø 150 - 200 - 250.....	TROGKONFIGURATION Ø 300 - 350 - 400 - 500 - 600.....	“ . 93
	SHIPPING DATA Ø 300 - 350 - 400 - 500 - 600.....	KOLLIDATEN Ø 150 - 200 - 250.....	“ . 94
		KOLLIDATEN Ø 300 - 350 - 400 - 500 - 600.....	“ . 94

2	MAINTENANCE CATALOGUE	WARTUNGSKATALOG	
	OPERATION AND MAINTENANCE.....	BETRIEBS- UND WARTUNGSANLEITUNG.....	M . 5 → . 37

3	SPARE PARTS CATALOGUE	ERSATZEILKATALOG	
	SPARE PARTS.....	ERSATZEILKATALOG.....	R . 5 → . 26

1 CATALOGUE TECHNIQUE

CODES ET SIGLES.....	
INTRODUCTION.....	
COMPOSITION STANDARD.....	
VARIANTES ET ACCESSOIRES.....	
ENCOMBREMENT.....	
COMPOSANTS MECANQUES.....	
COMPOSANTS STRUCTURE.....	
FINITION DES SURFACES SSC1.....	
TONALITES SSC1.....	
FINITION VIS SANS.....	
FINITION DES SURFACES SSC2X.....	
CODE MODULAIRE.....	
FICHE DE DEMANDE.....	
AUGE COMPOSEE.....	
FLASQUE COTE MOTORISATION.....	
FLASQUED'EXTREMITE FAUSSE.....	
SPIRE - ACIER AU CARBONE INOX 304L ET INOX 316L.....	
ACCOUPLLEMENT XAZ.....	
REVETEMENT HDPE.....	
BOUCHE DE DECHARGE XBY.....	
CAPOTAGE.....	
FERMETURE CAPOTAGE.....	
SUPPORTS PALIERS D'EXTREMITE TYPE XSV.....	
ETANCHEITE TYP XUC.....	
MOTEUR MT.....	
OPTIONS - REDUCTEUR TYPE S 21-23 - 25 - 27.....	
OPTIONS - MOTOREDUCTEUR A ROUE ET VIS SANS FIN.....	
OPTIONS - REDUCTEUR TYPE RA70.....	
OPTIONS - REDUCTEUR TYPE RA85 - 100 - 150.....	
OPTIONS - REDUCTEUR TYPE P 23 - 25 - 27.....	
OPTIONS - REDUCTEUR TYPE FZAF 88.....	
OPTIONS - REDUCTEUR TYPE FZAF 108.....	
OPTIONS - FLASQUE PORTE ETANCHEITE POUR RA.....	
OPTIONS - ENTRAINEMENT PAR COURROIES (REDUCTEUR TYPE "R - S").....	
OPTIONS - ENTRAINEMENT PAR CHAINE (REDUCTEUR TYPE "S").....	
OPTIONS - ENTRAINEM. AV.ACCOUP.L. DEMI-ELASTIQUE (RED. TYPE "S").....	
OPTIONS - REVETEMENT UHMWPE.....	
OPTIONS - REVETEMENT UHMWPE MAJORE.....	
OPTIONS - PLAQUE D'USURE BOULONNEE XJF.....	
ACCESSOIRES - BARRES D'USURE SOUDEES XJB.....	
ACCESSOIRES - BARRES D'USURE BOULONNEES XJB.....	
OPTIONS - BOUCHE D'ENTREE XBQ.....	
OPTIONS - BOUCHE D'ENTREE XBV.....	
OPTIONS - BOUCHE D'ENTREE XBR.....	
ACCESSOIRES - BOUCHE DE CHARGE CYLINDRIQUE XBC.....	
OPTIONS - BOUCHE DE DECHARGE CYLINDRIQUE XBC.....	
OPTIONS - DECHARGE AXIALE XBW.....	
ACCESSOIRES - DECHARGE ADDITIONNELLE XBQ.....	
OPTIONS - AUGES INTEGRALES.....	
OPTIONS - DECHARGE AXIALE TYPE ZBAS.....	
OPTIONS - BOUCHE DE DECHARGEMENT ZBAS SOUDEE.....	
OPTIONS - BOUCHE D'ENTREE ZBQ.....	
OPTIONS - BOUCHE D'ENTREE ZBR.....	
OPTIONS - BOUCHE D'ENTREE ZBI.....	
ACCESSOIRES - DECHARGE ADDITIONNELLE XBV.....	
ACCESSOIRES - DECHARGE ADDITIONNELLE XBR.....	
ACCESSOIRES - GROUPE DREINAGE.....	
ACCESSOIRES - REHAUSSE D'AUGE XZS.....	
ACCESSOIRES - REHAUSSE DE FLASQUE XPR.....	
ACCESSOIRES - CAPOT MOBILE XFBA.....	
ACCESSOIRES - GRILLE SOUS CAPOT MOBILE XKX.....	
ACCESSOIRES - SUPPORT CAPOT XJQ.....	
OPTIONS - GUIDE SPIRE XZG.....	
OPTIONS - DECHARGE AXIALE FWB.....	
OPTIONS - SPIRE DOUBLE FILET - ACIER AU CARBONE ET INOX 304L.....	
ACCESSOIRES - SEMELLE SUPPORT XJS.....	
ACCESSOIRES - PINCE A VIS XKM.....	
ACCESSOIRES - PLOUAGE ET BOUCHON.....	
ACCESSOIRES - BUSE D'ASPERSION XKU.....	
ACCESSOIRES - BRIDES CORNIERES.....	
ACCESSOIRES - CARTER MTR TYPE RA.....	
ACCESSOIRES - PIEDS REGLABLES.....	
ACCESSOIRES - GROUPE VIDANGE EAU.....	
ACCESSOIRES - PRESSEUR POUR PIPE.....	
ACCESSOIRES - RACCORD LATERAL.....	
POIDS.....	
DISPOSITION CONSTRUCTIVE Ø 150 - 200 - 250.....	
DISPOSITION CONSTRUCTIVE Ø 300 - 350 - 400 - 500 - 600.....	
COLISAGE Ø 150 - 200 - 250.....	
COLISAGE Ø 300 - 350 - 400 - 500 - 600.....	

1 CATALOGO TECNICO

CODICI E SIGLE.....	T. 5
INTRODUZIONE.....	" 6
FORNITURA STANDARD.....	" 7
VARIANTI E ACCESSORI.....	" 8 → 9
INGOMBRI COCLEA.....	" 10
COMPONENTI MECCANICA.....	" 11
COMPONENTI CARPENTERIA.....	" 12
FINITURA DELLE SUPERFICI SSC1.....	" 13
TONALITÀ SSC 1.....	" 14
FINITURA COCLEA.....	" 15 → 16
FINITURA DELLE SUPERFICI SSC2X.....	" 17 → 18
CHIAVE SIGLA MODULARE.....	" 19 → 23
MODULO RICHIESTA.....	" 24
TRUOGOLO COMPOSTO.....	" 25
PORTASUPPORTO LATO MOTORIZZAZIONE.....	" 26 → 27
PORTASUPPORTO CIECO.....	" 28
ELICA ACCIAIO AL CARBONIO, AISI304L E AISI 316L.....	" 29
ACCOUPLAMENTO XAZ.....	" 30
RIVESTIMENTO HDPE.....	" 31
BOCCA SCARICO XBY.....	" 32
COPERCHIO.....	" 33
CHIUSURA COPERCHIO.....	" 34
SUPPORTI D'ESTREMITÀ XSV.....	" 35
TENUTA XUC.....	" 36
MOTORE MT.....	" 37 → 38
OPZIONI - TESTATA MOTRICE S 21-23 - 25 - 27.....	" 39 → 42
OPZIONI - MOTORIZZAZIONE VITE SENZA FINE.....	" 43 → 46
OPZIONI - TESTATA MOTRICE RA 70.....	" 47
OPZIONI - TESTATA MOTRICE RA 85-100-150.....	" 48
OPZIONI - TESTATA MOTRICE P 23 - 25 - 27.....	" 49
OPZIONI - TESTATA MOTRICE FZAF 88.....	" 50
OPZIONI - TESTATA MOTRICE FZAF 108.....	" 51
OPZIONI - FLANGIA PORTATENUTA PER RA.....	" 52
OPZIONI - TRASMISSIONE A CINGHIE (TEST.MOTR.TIPO "R - S").....	" 53
OPZIONI - TRASMISSIONE A CATENA (TEST.MOTR.TIPO "S").....	" 54
OPZIONI - TRASMISSIONE CON GIUNTO (TEST.MOTR.TIPO "S").....	" 55
OPZIONI - RIVESTIMENTO UHMWPE.....	" 56
OPZIONI - RIVESTIMENTO MAGGIORATO BICOLORE UHMWPE.....	" 57
OPZIONI - PIATTO DI FONDO IMBULLONATO XJF.....	" 58
ACCESSORI - BARRE DI FONDO SALDATE XJB.....	" 59
ACCESSORI - BARRE DI FONDO IMBULLONATE XJB.....	" 60
OPZIONI - BOCCA CARICO XBQ.....	" 61
OPZIONI - BOCCA CARICO XBV.....	" 62
OPZIONI - BOCCA CARICO XBR.....	" 63
ACCESSORI - BOCCA CARICO CILINDRICA XBC.....	" 64
OPZIONI - BOCCA SCARICO CILINDRICA XBC.....	" 65
OPZIONI - SCARICO ASSIALE XBW.....	" 66
ACCESSORI - BOCCA SCARICO SUPPLEMENTARE XBQ.....	" 67
OPZIONI - TRUOGOLO INTEGRALE.....	" 68
OPZIONI - SCARICO ASSIALE TIPO ZBAS.....	" 69
OPZIONI - BOCCA SCARICO ZBSR SALDATA.....	" 70
OPZIONI - BOCCA CARICO ZBQ.....	" 71
OPZIONI - BOCCA CARICO ZBR.....	" 72
OPZIONI - BOCCA CARICO ZBI.....	" 73
ACCESSORI - BOCCA SCARICO SUPPLEMENTARE XBV.....	" 74
ACCESSORI - BOCCA SCARICO SUPPLEMENTARE XBR.....	" 75
ACCESSORI - GRUPPO DRENAGGIO.....	" 76
ACCESSORI - SPONDE RIALZATE XZS.....	" 77
ACCESSORI - PORTASUPPORTO DI RIALZO XPR.....	" 78
ACCESSORI - PORTELLO XFBA.....	" 79
ACCESSORI - RETE SOTTO PORTELLO XKX.....	" 80
ACCESSORI - SOTTOCOPERCHIO XJQ.....	" 81
OPZIONI - GUIDA ELICA XZG.....	" 82
OPZIONI - SCARICO ASSIALE FWB.....	" 83
OPZIONI - ELICA DOPPIA - ACCIAIO AL CARBONIO E AISI 304L.....	" 84
ACCESSORI - SELLA XJS.....	" 85
ACCESSORI - MORSETTO A VITE XKM.....	" 86
ACCESSORI - MANICOTTO E TAPPO.....	" 87
ACCESSORI - UGELLO XKU.....	" 88
ACCESSORI - STAFFE ANGOLARI.....	" 89
ACCESSORI - CARTER MTR TIPO RA.....	" 90
ACCESSORI - PIEDI REGOLABILI 1000 - 500 mm.....	" 91 → 92
ACCESSORI - GRUPPO SCARICO ACQUA.....	" 93
ACCESSORI - PRESSORE PER ELICA.....	" 94
ACCESSORI - INNESTO LATERALE.....	" 95
PESO.....	" 96
DISPOSIZIONE TRUOGOLI Ø 150 - 200 - 250.....	" 97
DISPOSIZIONE TRUOGOLI Ø 300 - 350 - 400 - 500 - 600.....	" 98
INGOMBRI SPEDIZIONE Ø 150 - 200 - 250.....	" 99
INGOMBRI SPEDIZIONE Ø 300 - 350 - 400 - 500 - 600.....	" 100

2 CATALOGUE D'ENTRETIEN

UTILISATION ET ENTRETIEN.....

CATALOGO DI MANUTENZIONE

USO E MANUTENZIONE..... M . 5 → 37

3 CATALOGUE PIECES DE RECHANGE

PIECES DE RECHANGE.....

CATALOGO RICAMBI

PEZZI DI RICAMBIO..... R . 5 → 26

ORDERING SPARE PARTS	ERSATZTEILBESTELLUNG	COMMANDE DE PIECES DE RECHANGE	ORDINAZIONE DEI PEZZI DI RICAMBIO
<p>A) Steel fabricated parts and bearing assemblies Please indicate serial n°. of the conveyor applied on each trough section, as well as page and item no. In this catalogue of the part concerned. Also indicate the required quantity of parts taking into consideration the minimum supply given in the price list.</p>	<p>A) Stahlbauteile und Lager-einheiten Folgende Angaben sind hierfür erforderlich: Produktions-Nr.der Schnecke (abzulesen auf jedem Schnecken-teil), Seitenzahl und Position im Katalog sowie die gewünschte Menge (Mindestmenge bitte der Preisliste entnehmen).</p>	<p>A) Pièces en charpente et pali-ers Quand vous passez une commande d'une pièce de rechange, nous vous prions de nous communiquer le N°. de fabrication que vous trouvez sur chaque section de la vis, le N° de la page et de la position de la pièce dans ce catalogue, ainsi que la quantité désirée en tenant compte du minimum indiqué dans la liste de prix.</p>	<p>A) Pezzi di carpenteria e di supporteria All'ordine sono da comunicare il N°. matricolare della coclea riportato su ogni spezzone della stes-sa, il N°. di pagina, il N°. o la lettera di posizione e la descrizione del pezzo nonché la quantità richiesta tenendo conto delle quantità minime riportate nel listino prezzi.</p>
<p>B) Gear reduction units and electric motors Instead of the screw serial n°. indicate serial n°. of gear reduction unit or of the electric motor and add information requested in paragraph A). Parts not included in price list cannot be supplied. These are: 1) Standard parts if not included in kits 2) Item numbers in brackets, i.e. single parts included in kits.</p>	<p>B) Getriebeeinheiten und Elektromotoren Anstelle der Produktions-Nr. der Schnecke ist die Produktions-Nr. des Getriebes bzw. des E-Motors anzugeben. Ansonsten sind die unter Punkt A bereits genannten Angaben hinzuzufügen. In der Preisliste nicht aufgeführte Positionen sind nicht lieferbar. Im einzelnen sind dies: 1) Normteile sofern die Montagesätze diese nicht beinhalten 2) in Klammern gesetzte Positionen bzw. Einzelteile zu den Montagesätzen.</p>	<p>B) Réducteurs et moteurs électriques Au lieu du N°. de fabrication de la vis il faut indiquer celui du réducteur ou du moteur. Ensuite ajoutez l'information demandée sous la lettre A). Les pièces qui ne sont pas comprises dans la liste de prix ne peuvent pas être fournies. En particulier ce sont: 1) Les pièces commerciales à normes européennes ne pas comprises dans les kits 2) Les positions entre parenthèses, c'est à dire les composants des kits.</p>	<p>B) Testate motrici e motori elettrici Al posto del N°. matricolare della coclea indicare quello della testata motrice o del motore elettrico. Quindi aggiungere le altre informazioni richieste sotto la lettera A). I prezzi non compresi nel listino prezzi non possono essere forniti. In particolare sono: 1) pezzi a norma se non compresi nei kits 2) numeri di posizione tra parentesi o singoli componenti dei kits.</p>
<p>Check minimum supply before making an order.</p>	<p>Vor der Auftragserteilung die in der Preisliste aufgeführten Mindestmengen für die jeweiligen Artikel prüfen.</p>	<p>Avant le passage d'une commande vérifier les quantités minimum dans la liste de prix.</p>	<p>Prima di passare un ordine verificare la quantità minima indicata nel listino prezzi.</p>
<p>General Supply Conditions are valid.</p>	<p>Es gelten die Allgemeinen Verkaufs- und Lieferbedingungen.</p>	<p>Nos Conditions Générales de Vente sont valables.</p>	<p>Sono valide le ns. Condizioni Generali di vendita.</p>

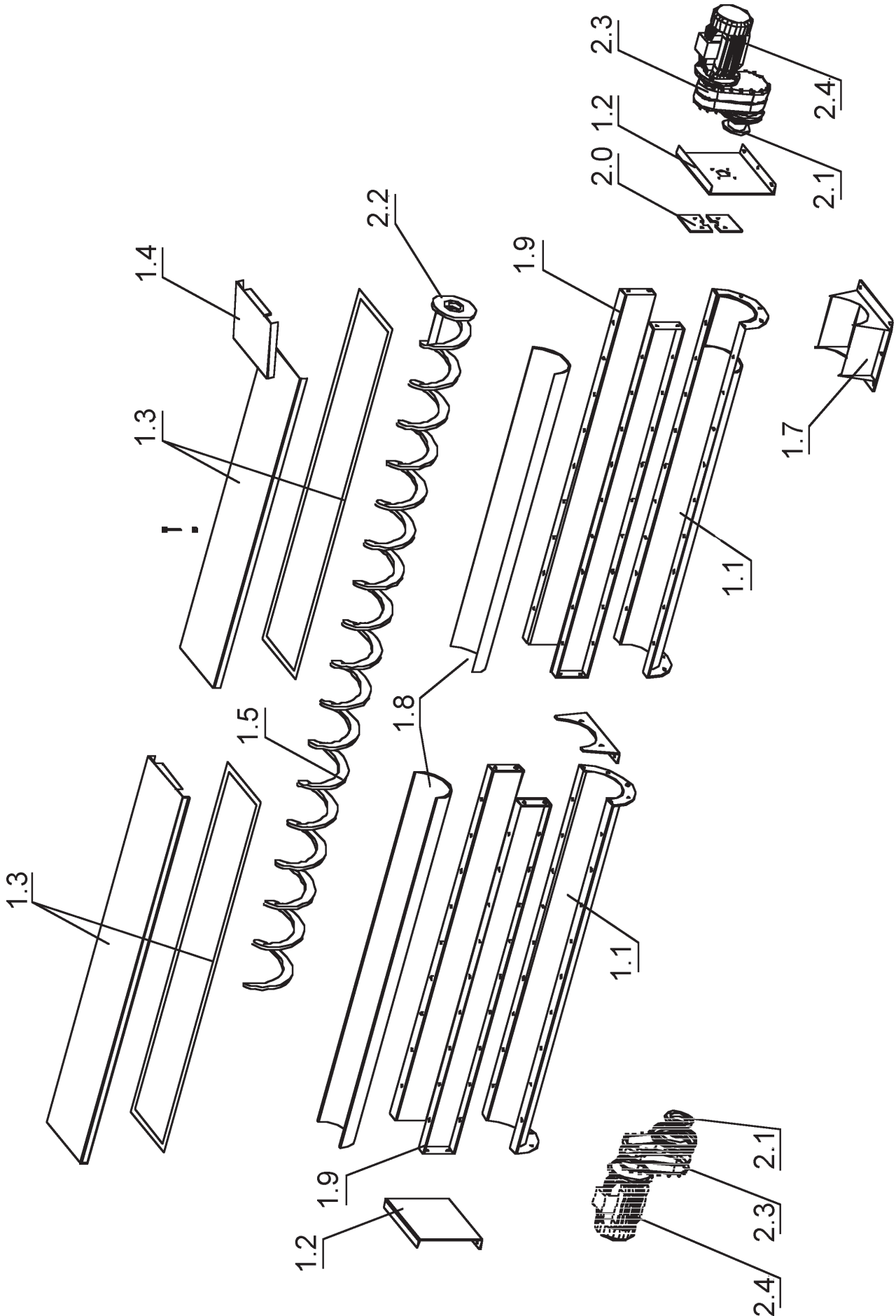

Item Pos. Pos. Pos.	DESCRIPTION	BENENNUNG	DESIGNATION	DENOMINAZIONE	Code
1	STRUCTURAL COMPON.	STAHLBAUTEILE	PARTIE STRUCTURE	PARTE CARPENTERIA	
1.1	Trough	Trog	Auge	Truogolo	XCU
1.2	End plate	Endschild	Flasque d'extrémité	Portasupporto	XPU
1.3	Cover + Gasket	Abdeckung + Dichtung	Couvercle + Joint	Coperchio + Guarnizione	XFC
1.4	Inspection door	Überlaufklappe	Capot mobile	Portello ispezione	XFBS
1.5	Spiral	Spirale	Spire	Spira	
1.7	Outlet	Auslauf	Bouche décharge	Bocca uscita	XBY
1.8	Liner	Trogauskleidung	Revêtement	Rivestimento	XJL
1.9	Trough side channel	Trogflanke	Bord d'auge	Sponda	
2.0	Gland	Wellendichtungsblech	Plaque	Piastra di tenuta	
3	MECHANICAL PARTS	MECHANISCHE TEILE	PARTIE MECANIQUE	PARTE MECCANICA	
3.1	Sealing	Wellenabdichtung	Etanchéite	Tenuta	XUC
3.2	Coupling	Wellenverbindung	Accouplement	Accoppiamento	XAZ
3.3	Gear box	Getriebe	Réducteur	Testata motrice	R.
3.4	Motor	Motor	Moteur	Motore	MT

Gear reduction head	series	S 21
Getriebe	serie	
Tête motrice	serie	
Testata motrice	serie	

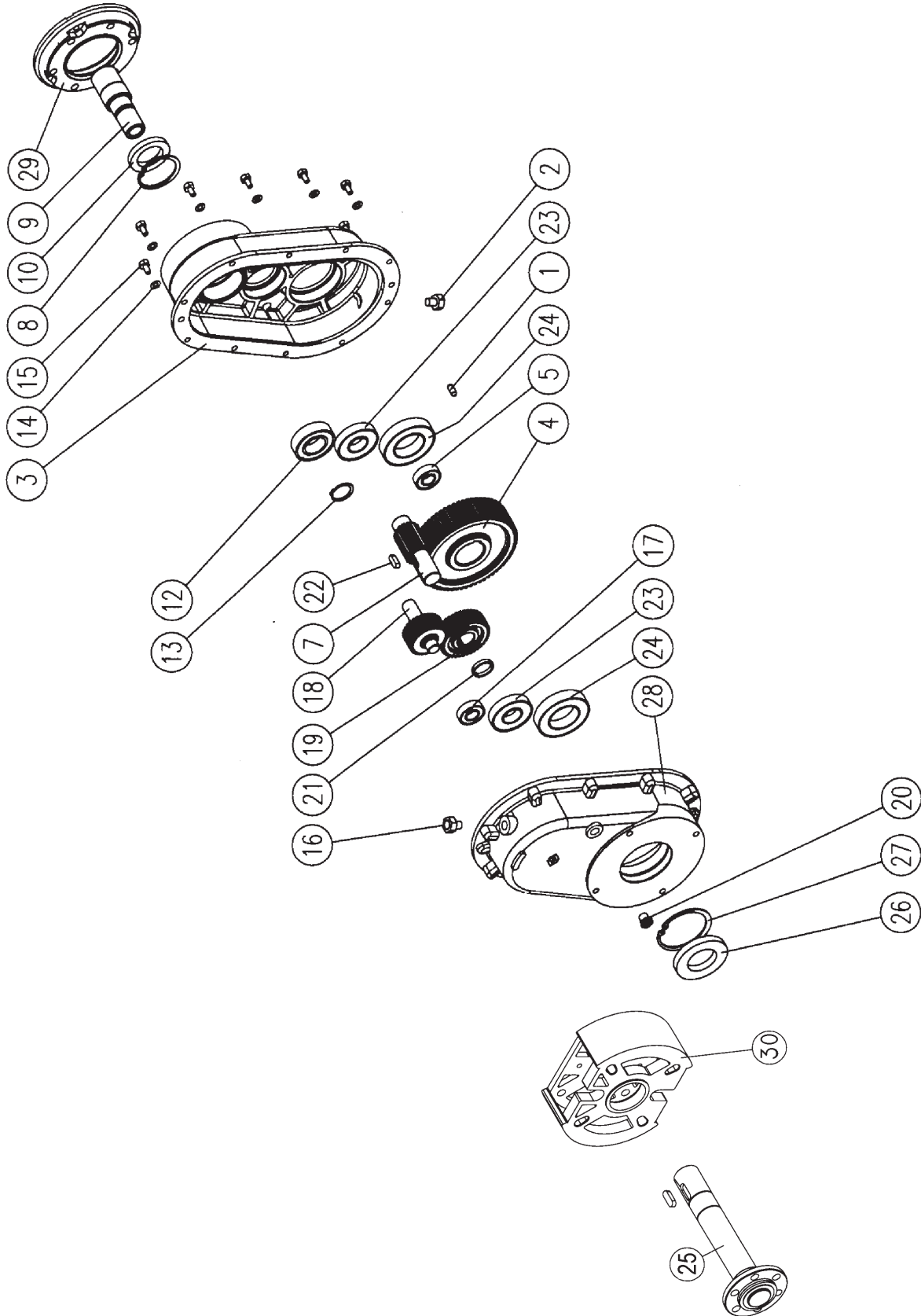

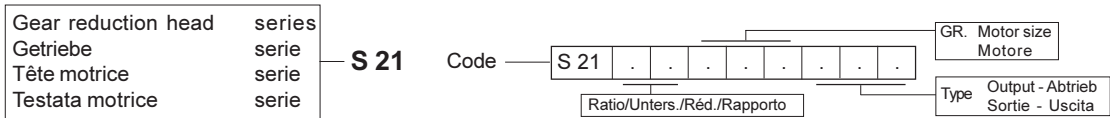

Item Pos.	Quant. Menge	Standards Normen Normes Norme	DESCRIPTION	BENENNUNG	DESIGNATION	DENOMINAZIONE	Code
			Sealing kit	Dichtungssatz	Kit étanchéité	Kit tenuta	13009900A
26	1	DIN 3760 NB	Rotary shaft seal	Wellendichtring	Joint d'étanchéité	Anello di tenuta	(62x30x7)
10	1	DIN 3760 NB	Rotary shaft seal	Wellendichtring	Joint d'étanchéité	Anello di tenuta	(72x45x8)
1	1	DIN 7	Cylindrical pin	Zylinderstift	Goupille cylindrique	Spina cilindrica	(Ø 10x20)
			Bearing kit	Lagersatz	Kit roulements	Kit cuscinetti	13009880A
12	1		Radial bearing	Radiatrollenkugellager	Roulement radial	Cuscinetto radiale	(6207)(35x72x17)
23	2		Radial bearing	Radiatrollenkugellager	Roulement radial	Cuscinetto radiale	(6203)(17x40x12)
24	2		Radial bearing	Radiatrollenkugellager	Roulement radial	Cuscinetto radiale	(6206)(30x62x16)
17	1		Radial bearing	Radiatrollenkugellager	Roulement radial	Cuscinetto radiale	(6202)(15x35x11)
			Retaining ring kit	Satz Sicherungsringe	Kit circlip "Seeger"	Kit seeger	13009890A
13	1	DIN 471	Retaining ring for shaft	Seegerring für Welle	Seeger pour arbre	Seeger per albero	(Ø 35)
27	1	DIN 472	Retaining ring for bore	Seegerring für Bohrung	Seeger pour perçage	Seeger per foro	(Ø 62)
8	1	DIN 472	Retaining ring for bore	Seegerring für Bohrung	Seeger pour perçage	Seeger per foro	(Ø 72)
14	13	DIN 912	Hexagon bolt	Sechskantschraube	VTH	Vite T.C.E.I.	(M 6x25)
15	13	DIN 125A	Washer	Unterlegscheibe	Rondelle	Rondella bisellata	(M 6)
			Elastic washer	Elastische Scheibe	Rondelle élastique	Rosetta elastica	(M 6)
2	1		Oil outlet plug	Ablassschraube	Bouchon de vidange	Tappo di scarico	(3/8")
			Casing	Gehäuse	Corps réducteur	Corpo riduttore	
3	1		Input casing	Gehäuse eingangsseite	Corps côté entrée	Corpo lato entrata	20920951A
28	1		Output casing	Gehäuse atriebsseite	Corps côté sortie	Corpo lato uscita	20920961A
			Input gear kit	Eingang	Entrée	Entrata PAM	
			Motor size 080	Baugröße 080	Bride moteur 080	Grandeza motore 080	
29	1		Input flange	Eingangsfansch	Bride entrée	Flangia entrata	20924051A
9	1		Hollow shaft	Hohlwelle	Embout entrée	Boccola entrata	20970161A
			Hexagonal screw	Innensechskantschraube	Vis	Vite T.C.E.I.	(10x50)
			Hexagonal screw	Sechskantschraube	Vis	Vite T.C.E.I.	(12x35)
			Washer	Unterlegscheibe	Rondelle	Rondelle	(13x24)
			Elastic washer	Elastische Scheibe	Rondelle élastique	Rondella elastica	(M12)

Gear reduction head series
 Getriebe serie
 Tête motrice serie
 Testata motrice serie

S 21

Code

S 21

Ratio/Unters./Réd./Rapporto

 GR. Motor size
 Motore

 Type Output - Abtrieb
 Sortie - Uscita

Item Pos.	Quant. Menge	Standards Normen Normes Norme	DESCRIPTION	BENENNUNG	DESIGNATION	DENOMINAZIONE	Code
			Input gear Ratio 1/40	Radsatz Eingangssseite Untersetzung 1:40	Engrainages d'entrée Reduction 1:40	Sottogruppo coppia entrata Rapporto riduttore 1:40	10752710A
18	1		Pinion	Ritzel	Pignon	Pignone	
19	1		Gear wheel	Zahnrad	Roue dentée	Corona	
22	1	DIN 6885	Parallel key	Passfeder	Clavette	Linguetta (5x5x16)	
			Output gear 1:30-1:40	Radsatz Abtriebsseite 1:30-1:40	Engrainages de sortie 1:30-1:40	Sottogruppo coppia uscita 1:30-1:40	10752700A
7	1		Pinion	Ritzel	Pignon	Pignone	
4	1		Gear wheel	Zahnrad	Roue dentée	Corona	
6	1	DIN 6885	Parallel key	Passfeder	Clavette	Linguetta (8x7)	
			Output A 6	Ausgang A 6	Sortie A 6	Uscita A 6	
30	1		Output flange	Ausgangsflansch	Bride sortie	Flangia uscita	20923111B
25	1		Output shaft	Abtriebswelle	Arbre sortie	Albero uscita	20947581A
			Hexagonal socket bolt	Innensechskantschraube	VHT	Vite T.C.E.I.	(10x35)
4	4	DIN 912	Hexagonal bolt	Sechskantschraube	VHT	Vite T.E.	(10x35)
			Washer	Unterlegscheibe	Rondelle	Rondella	(M 10)
			Elastic washer	Elastische Scheibe	Rondelle élastique	Rosetta elastica	(M 10)
			Felt ring	Filzring	Joint garniture	Anello di feltro	20989241A

Gear reduction head	series	S 23
Getriebe	serie	
Tête motrice	serie	
Testata motrice	serie	

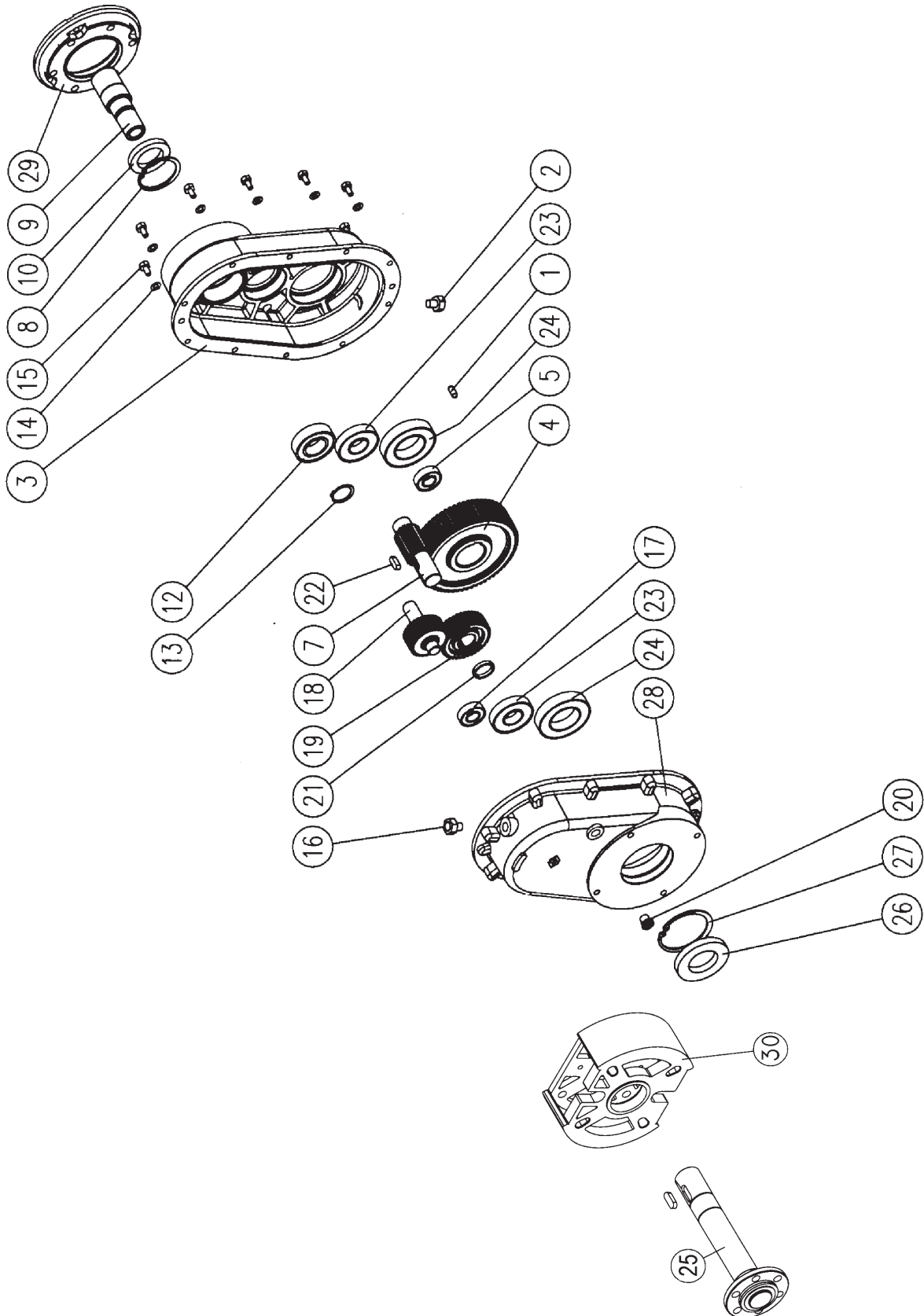

Gear reduction head series
Getriebe serie
Tête motrice serie
Testata motrice serie

S 23

Code

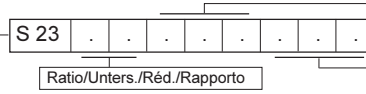

GR. Motor size
Motore

Type Output - Abtrieb
Sortie - Uscita

Item Pos.	Standards Quant. Menge	Description	Benennung	Designation	Denominazione	Code
		Sealing kit 90/100/112	Dichtungssatz 90/100/112	Kit étanchéité 90/100/112	Kit tenuta 30/100/112	13009500A
26	1	Rotary shaft seal	Wellendichtring	Joint d'étanchéité	Anello di tenuta	(80x40x10)
10	1	Rotary shaft seal	Wellendichtring	Joint d'étanchéité	Anello di tenuta	(80x45x10)
1	2	Cylindrical pin	Zylinderstift	Goupille cylindrique	Spina cilindrica	(10x20)
		Bearing kit	Lagersatz	Kit roulements	Kit cuscinetti	12009480A
12	1	Radial bearing	Radialrollenkugellager	Roulement radial	Cuscinetto radiale	(6206) (30x62x16)
23	1	Radial bearing	Radialrollenkugellager	Roulement radial	Cuscinetto radiale	(6304) (20x52x15)
24	2	Radial bearing	Radialrollenkugellager	Roulement radial	Cuscinetto radiale	(6208) (40x80x18)
17		Radial bearing	Radialrollenkugellager	Roulement radial	Cuscinetto radiale	(6303) (17x47x14)
		Retaining ring kit	Satz sicherungsringe	Kit circlip "seeger"	Kit seeger	13009490A
13	2	Retaining ring for shaft	Seegerring für Welle	Seeger pour arbre	Seeger per albero	(Ø30)
27	2	Retaining ring for bore	Seegerring für Bohrung	Seeger pour perçage	Seeger per foro	(Ø62)
8	1	Retaining ring for bore	Seegerring für Bohrung	Seeger pour perçage	Seeger per foro	(Ø80)
14		Hexagon socket bolt	Innensechskantschraube	VTH	Vite T.C.E.I.	(M8x2,5)
15	1	Washer	Unterlegscheibe	Rondelle	Rondella bisellata	(M8)
		Elastic washer	Elastische Scheibe	Rondelle élastique	Rosetta elastica	(M8)
		Oil plug kit	Ölschraubensatz	Kit lubrification	Kit tappi lubrificazione	13008330A
16	10	Breather plug	Entlüftungsschraube	Bouchon reniflard	Tappo di carico e sfiato	(3/8")
2	20	Oil outlet plug	Ablassschraube	Bouchon de vidange	Tappo di scarico	(3/8")
20	10	Oil level plug	Ölstandschraube	Bouchon de niveau	Indicatore di livello a vista	(3/8")
		Casing	Gehäuse	Corps réducteur	Corpo riduttore	
3	1	Input casing	Gehäuse Eingangsseite	Corps côté entrée	Corpo lato entrata	20920901A
28	1	Output casing	Gehäuse Atriebsseite	Corps côté sortie	Corpo lato uscita	20920911A

Gear reduction head series
 Getriebe serie
 Tête motrice serie
 Testata motrice serie

S 23

Code

S 23

Ratio/Unters./Réd./Rapporto

GR. Motor size
MotoreType Output - Abtrieb
Sortie - Uscita

Item Pos.	Quant. Menge	Standards Normen Normes Norme	Description	Benennung	Designation	Denominazione	Code
			Input	Eingang	Entrée	Entrata PAM	
			Motor size 090	Baugrosse 090	Bride moteur 090	Grandezza motore 090	
29	1		Input flange	Eingangsfansch	Bride entrée	Flangia entrata	20924061A
9	1		Hollow shaft	Hohlwelle	Embout entrée	Boccola entrata	209QDOK1A
	6	DIN 912	Hexagon socket bolt	Innensechskantschraube	Vis	Vite T.C.E.I.	(M10x50)
	4	DIN 912	Hexagon socket bolt	Innensechskantschraube	Vis	Vite T.C.E.I.	(M10x30)
	4	DIN 125 A	Washer	Unterlegscheibe	Rondelle	Rondelle	(M10)
	4	DIN 127 B	Elastic washer	Elastische Scheibe	Rondelle élastique	Rondella elastica	(M10)
			Input	Eingang	Entrée	Entrata PAM	
			Motor size 100 - 112	Baugrosse 100 - 112	Bride moteur 100 - 112	Grandezza motore 100-112	
29	1		Input flange	Eingangsfansch	Bride entrée	Flangia entrata	20924091A
9	1		Hollow shaft	Hohlwelle	Embout entrée	Boccola entrata	209QDOC1A
	6	DIN 912	Hexagon socket bolt	Innensechskantschraube	Vis	Vite T.C.E.I.	(M10x50)
	4	DIN 912	Hexagon socket bolt	Innensechskantschraube	Vis	Vite T.C.E.I.	(M10x30)
	4	DIN 125 A	Washer	Unterlegscheibe	Rondelle	Rondelle	(M10)
	4	DIN 127 B	Elastic washer	Elastische Scheibe	Rondelle élastique	Rondella elastica	(M10)
			Output gear	Radsatz Artreibsseite	Engrenages de sortie	Sottogruppo coppia uscita	10752450A
			Ratio 1/30 - 1/40	Untersetzung 1:30 - 1:40	Réduction 1:30 - 1:40	Rapporto riduttore 1:30 - 1:40	
18	1		Pinion	Ritzel	Pignon	Pignone	
19	1		Gear wheel	Zahnrad	Roue dentée	Corona	
22	1	DIN 6885	Parallel key	Passfeder	Clavette	Linguetta	(12x8x32)
			Spacer	Distanzring	Entretoise	Distanziale	20984891A
			Spacer	Distanzring	Entretoise	Distanziale	20984881A
			Input gear	Radsatz Eingangsseite	Engrenages d'entrée	Sottogruppo coppia entrata	
			Ratio 1/40	Untersetzung 1:40	Réduction 1:40	Rapporto riduttore 1:40	
18	1		Pinion	Ritzel	Pignon	Pignone	
19	1		Gear wheel	Zahnrad	Roue dentée	Corona	
22	1	DIN 6885	Parallel key	Passfeder	Clavette	Linguetta	(6x6x20)
			Output A6	Ausgang A6	Sortie A6	Uscita A6	
30	1		Output flange	Ausgangsfansch	Bride sortie	Flangia uscita	20924171B
25	1		Output shaft	Abtriebswelle	Arbre sortie	Albero uscita	20947471A
	4	DIN 933	Hexagon bolt	Sechskantschraube	VHT	Vite T.E.	(M10x150)
	4	DIN 127B	Elastic washer	Elastische Scheibe	Rondelle élastique	Rosetta elastica	(M10)
	4	DIN 125A	Washer	Scheibe	Rondelle	Rondella bisellata	(M10)
	1		Felt ring	Filzring	Joint garniture	Anello di feltro	20989231A

Gear reduction head	serie	
Getriebe	serie	
Tête motrice	serie	S 25
Testata motrice	serie	

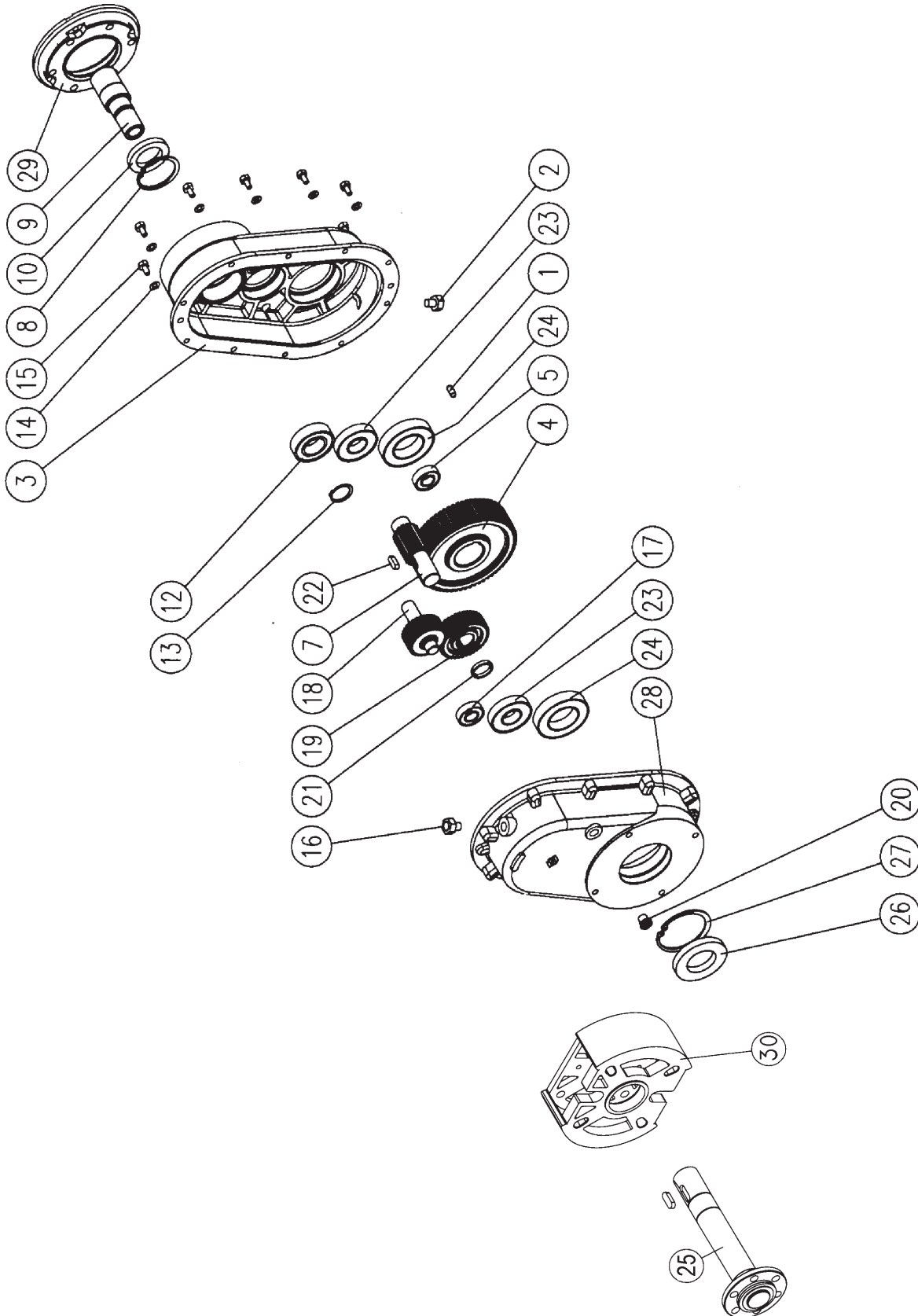

Gear reduction head series
 Getriebe serie
 Tête motrice serie
 Testata motrice serie

S 25

Code

S 25
 Ratio/Unters./Réd./Rapporto

GR. Motor size
MotoreType Output - Abtrieb
Sortie - Uscita

Item Pos.	Standards Quant. Menge	Normen Normes Norme	DESCRIPTION	BENENNUNG	DESIGNATION	DENOMINAZIONE	Code
			Sealing kit 90/110/112	Dichtungssatz 90/110/112	Kit étanchéité 90/110/112	Kit tenuta 90/110/112	13009180A
26	1	DIN 3760 NB	Rotary shaft seal	Weilendichtring	Joint d'étanchéité	Anello di tenuta	(90x50x10)
10	1	DIN 3760 NB	Rotary shaft seal	Weilendichtring	Joint d'étanchéité	Anello di tenuta	(80x45x10)
1	2	DIN 7	Cylindrical pin	Zylinderstift	Goupille cylindrique	Spina cilindrica	(10x20)
			Sealing kit GR 132	Dichtungssatz GR 132	Kit étanchéité GR 132	Kit tenuta GR 132	13009190A
26	1	DIN 3760 NB	Rotary shaft seal	Weilendichtring	Joint d'étanchéité	Anello di tenuta	(90x50x10)
10	1	DIN 3760 NB	Rotary shaft seal	Weilendichtring	Joint d'étanchéité	Anello di tenuta	(80x55x10)
1	2	DIN 7	Cylindrical pin	Zylinderstift	Goupille cylindrique	Spina cilindrica	(10x20)
			Bearing kit	Lagersatz	Kit roulements	Kit cuscinetti	13008300A
12	1		Radial bearing	Radialrollenkugellager	Roulement radial	Cuscinetto radiale	6307 (35x80x21)
23	2		Radial bearing	Radialrollenkugellager	Roulement radial	Cuscinetto radiale	6306 (30x72x19)
24	2		Radial bearing	Radialrollenkugellager	Roulement radial	Cuscinetto radiale	6210 (50x90x20)
17	1		Radial bearing	Radialrollenkugellager	Roulement radial	Cuscinetto radiale	6304 (20x52x15)
			Retaining ring kit	Satz Sicherungsringe	Kit circlip "Seeger"	Kit seeger	13008320A
13	1	DIN 471	Retaining ring for shaft	Seegerring für Welle	Seeger pour arbre	Seeger per albero	(Ø35)
27	2	DIN 472	Retaining ring for bore	Seegerring für Bohrung	Seeger pour perçage	Seeger per foro	(Ø80)
8	1	DIN 472	Retaining ring for bore	Seegerring für Bohrung	Seeger pour perçage	Seeger per foro	(Ø90)
14	10	DIN 912	Hexagon socket bolt	Innensechskantschraube	VTH	Vite T.C.E.I.	(M8x25)
15	20	DIN 125-A	Washer	Unterlegscheibe	Rondelle	Rondella bisellata	(M8)
			Elastic washer	Elastische Scheibe	Rondelle élastique	Rosetta elastica	(M8)
			Oil plug kit	Ölschraubensatz	Kit lubrification	Kit tappi lubrificazione	13008330A
16	1		Breather plug	Entlüftungsschraube	Bouchon reniflard	Tappo di carico e sfiato	(3/8")
2	1		Oil outlet plug	Ablassschraube	Bouchon de vidange	Tappo di scarico	(3/8")
20	1		Oil level plug	Ölstandschraube	Bouchon de niveau	Indicatore di livello a vista	(3/8")
			Casing	Gehäuse	Corps réducteur	Corpo riduttore	
	1		Input casing	Gehäuse Eingangsseite	Corps côté entrée	Corpo lato entrata	20920881A
	1		Output casing	Gehäuse Abtriebsseite	Corps côté sortie	Corpo lato uscita	20920891A

Gear reduction head
Getriebe
Tête motrice
Testata motrice

series
serie
serie
serie

S 25

Code

S 25

Ratio/Unters./Réd./Rapporto

GR. Motor size
MotoreType Output - Abtrieb
Sortie - Uscita

Item Quant. Pos. Menge	Standards Normen Normes Norme	DESCRIPTION	BENENNUNG	DESIGNATION	DENOMINAZIONE	Code
		Input	Eingang	Entrée	Entrata PAM	
		Motor size 100 - 112	Baugröße 100 - 112	Bride moteur 100 - 112	Grandezza motore 100 - 112	20924101A
29	1	Input flange	Eingangsfansch	Bride entrée	Flangia entrata	20924101A
9	1	Hollow shaft	Hohlwelle	Embout entrée	Boccola entrata	209QD041A
	6	Hexagon socket bolt	Innensechskantschraube	Vis	Vite T.C.E.I.	(M12x35)
	4	Hexagon bolt	Sechskantschraube	Vis	Vite T.E.	(M10x30)
	4	Washer	Unterlegscheibe	Rondelle	Rondella	(M10)
	4	Elastic washer	Elastische Scheibe	Rondelle élastique	Rondella elastica	(M10)
		Input	Eingang	Entrée	Entrata PAM	
		Motor size 132	Baugröße 132	Bride moteur 132	Grandezza motore 132	20924131A
29	1	Input flange	Eingangsfansch	Bride entrée	Flangia entrata	20924131A
9	1	Hollow shaft	Hohlwelle	Embout entrée	Boccola entrata	209QD051A
	6	Hexagon socket bolt	Innensechskantschraube	Vis	Vite T.C.E.I.	(M12x35)
	4	Hexagon bolt	Sechskantschraube	Vis	Vite T.E.	(M10x30)
	4	Washer	Unterlegscheibe	Rondelle	Rondella	(M10)
	4	Elastic washer	Elastische Scheibe	Rondelle élastique	Rondella elastica	(M10)
		Input gear	Radsatz Eingangsseite	Engrainages d'entrée	Sottogruppo coppia entrata	10752190A
		Ratio 1/40	Untersetzung 1:40	Réduction 1:40	Rapporto riduttore 1:40	
18	1	Pinion	Ritzel	Pignon	Pignone	
19	1	Gear wheel	Zahnrad	Roue dentée	Corona	
22	1	Parallel key	Passfeder	Clavette	Linguetta	
		Output gear	Radsatz Ausgangsseite	Engrainages sortie	Sottogruppo coppia uscita	10752130A
		Ratio 1/30 - 1/40	Untersetzung 1:30 - 1:40	Réduction 1:30 - 1:40	Rapporto riduttore 1:30 - 1:40	
7	1	Pinion	Ritzel	Pignon	Pignone	
4	1	Gear wheel	Zahnrad	Roue dentée	Corona	
6	1	Parallel key	Passfeder	Clavette	Linguetta	
		Spacer	Distanzring	Entretoise	Distanziale	20984831A
		Spacer	Distanzring	Entretoise	Distanziale	20984841A
		Spacer	Distanzring	Entretoise	Distanziale	20984851A
		Output A 6	Ausgang A 6	Sortie A 6	Uscita A 6	
30	1	Output flange	Ausgangsfansch	Bride sortie	Flangia uscita	20923161B
25	1	Output shaft	Abtriebswelle	Arbre sortie	Albero uscita	20947421A
	4	Hexagon bolt	Sechskantschraube	VTH	Vite T.E.	(M12x170)
	4	Elastic washer	Elastische Scheibe	Rondelle élastique	Rosetta elastica	(M12)
	4	Washer	Scheibe	Rondelle biseautée	Rondella bisellata	(M12)
	1	Hexagonal nut	Hexagonal nut	Écrou hexagon	Dado esagonale	(M12)
	4	Hexagon Bolt	Sechskantschraube	VHT	Vite T.E.	(M12x45)
	4	Washer	Unterlegscheibe	Rondelle	Rondella	(M12)
	4	Elastic washer	Elastische Scheibe	Rondelle élastique	Rosetta elastica	(M12)
		Felt ring	Filzring	Joint garniture	Anello feltro	20989261B

Gear reduction head	series	S 27
Getriebe	serie	
Tête motrice	serie	
Testata motrice	serie	

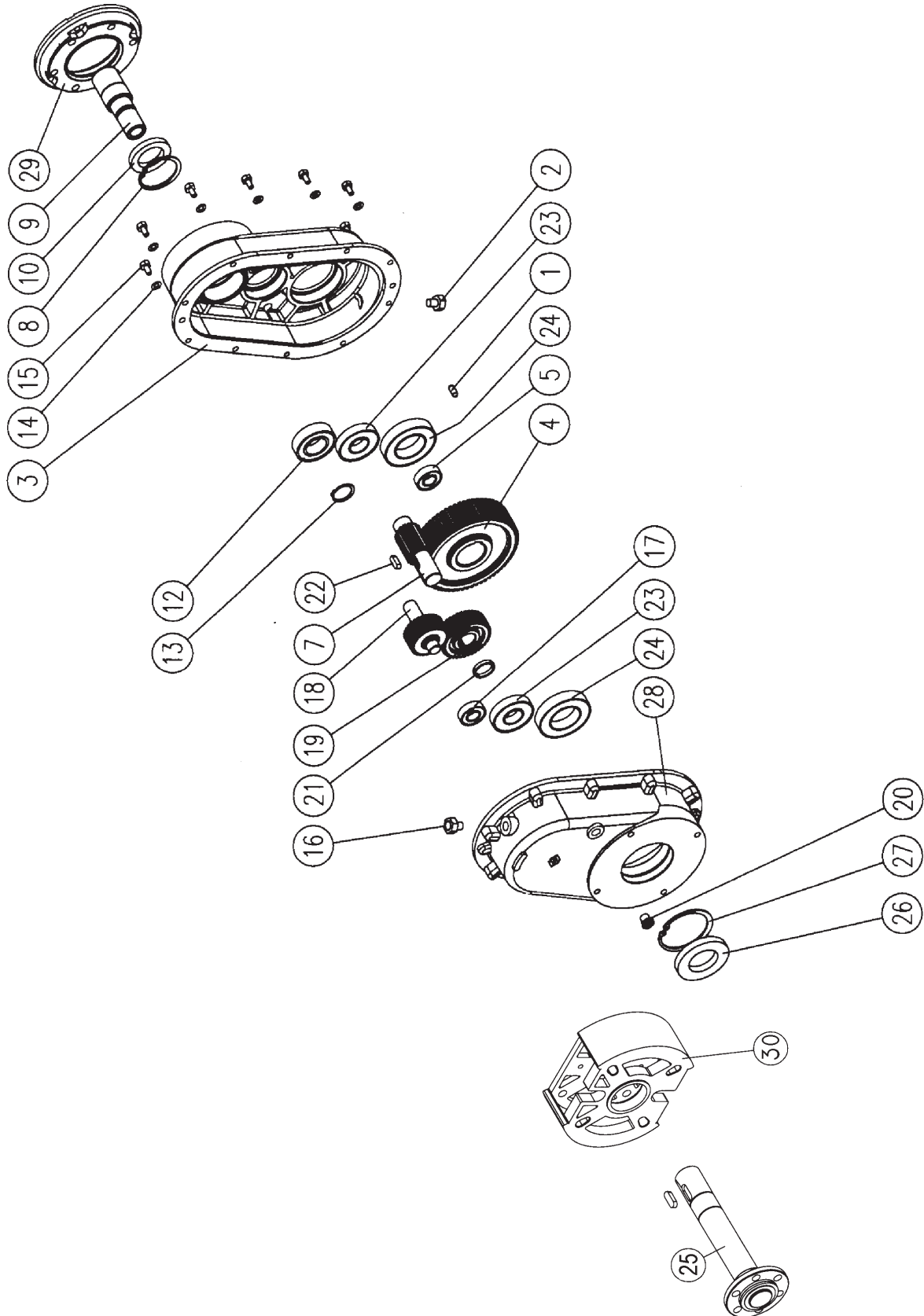

Gear reduction head series
Getriebe serie
Tête motrice serie
Testata motrice serie

S 27

Code

S 27

Ratio/Unters./Réd./Rapporto

GR. Motor size
MotoreType Output - Abtrieb
Sortie - Uscita

Item Pos.	Standards Quant. Normen Normes Norme	DESCRIPTION	BENENNUNG	DESIGNATION	DENOMINAZIONE	Code
		Sealing kit 112/132/160/180	Dichtungssatz 112/132/160/180	Kit étanchéité 112/132/160/180	Kit tenuta 112/132/160/180	13009770A
	1	Gasket	Flachdichtung	Garniture	Guarnizione riduttore	
26	1	DIN 3760 NB Rotary shaft seal	Wellendichtring	Joint d'étanchéité	Anello di tenuta (110x60x10)	
10	1	DIN 3760 NB Rotary shaft seal	Wellendichtring	Joint d'étanchéité	Anello di tenuta (100x70x10)	
1	2	DIN 7 Cylindrical pin	Zylinderstift	Goupille cylindrique	Spina cilindrica (10x20)	
		Bearing kit	Lagersatz	Kit roulements	Kit cuscinetti	13009750A
12	1	Radial bearing	Radialrollenkugellager	Roulement radial	Cuscinetto radiale 6309 (45x100x25)	
23	2	Radial bearing	Radialrollenkugellager	Roulement radial	Cuscinetto radiale 6307 (35x80x21)	
24	2	Radial bearing	Radialrollenkugellager	Roulement radial	Cuscinetto radiale 6212 (60x110x22)	
17	1	Radial bearing	Radialrollenkugellager	Roulement radial	Cuscinetto radiale 6305 (25x62x17)	
		Retaining ring kit	Satz sicherungsringe	Kit circlip "seeger"	Kit seeger	13009760A
13	1	DIN 471 Retaining ring for shaft	Seegerring für Welle	Seeger pour arbre	Seeger per albero (Ø 45)	
27	1	DIN 472 Retaining ring for bore	Seegerring für Bohrung	Seeger pour perçage	Seeger per foro (Ø 100)	
8	1	DIN 472 Retaining ring for bore	Seegerring für Bohrung	Seeger pour perçage	Seeger per foro (Ø 110)	
14	10	DIN 912 Hexagonal socket bolt	Innensechskantschraube	Vis	Vite T.C.E.I. (M12 x35)	
15	10	DIN 125A Washer	Unterlegscheibe	Rondelle	Rondella bisellata (M12)	
		Elastic washer	Elastische Scheibe	Rondelle élastique	Rosetta elastica (M12)	
		Oil plug kit	Ölschraubensatz	Kit lubrification	Kit tappi lubrificazione	13008330A
16	1	Breather plug	Entlüftungsschraube	Bouchon reniflard	Tappo di carico e sfiato (3/8")	
2	1	Oil outlet plug	Ablassschraube	Bouchon de vidange	Tappo di scarico (3/8")	
20	1	Oil level plug	Ölstandschraube	Bouchon de niveau	Indicatore di livello a vista (3/8")	
		Casing	Gehäuse	Corps réducteur	Corpo riduttore	
3	1	Input casing	Gehäuse Eingangsseite	Corps côté entrée	Corpo lato entrata	20920971A
28	1	Output casing	Gehäuse Abtriebsseite	Corps côté sortie	Corpo lato uscita	20920981A
		Input	Eingang	Entrée	Entrata PAM	
		Motor size 112	Baugrosse 112	Bride moteur 112	Grandezza motore 112	
29	1	Input flange	Eingangsfansch	Bride entrée	Flangia entrata	20924111A
9	1	Hollow shaft	Hohlwelle	Embout entrée	Boccola entrata	20970501A
	6	DIN 912 Hexagonal socket bolt	Innensechskantschraube	Vis	Vite T.C.E.I. (M12 x50)	
	4	DIN 912 Hexagonal socket bolt	Innensechskantschraube	Vis	Vite T.C.E.I. (M12x35)	
	4	DIN 125A Washer	Unterlegscheibe	Rondelle	Rondelle (M12)	
	4	DIN 127B Elastic washer	Elastische Scheibe	Rondelle élastique	Rondella elastica (M12)	

Gear reduction head series
 Getriebe serie
 Tête motrice serie
 Testata motrice serie

S 27

Code

S 27
 Ratio/Unters./Réd./Rapporto

GR. Motor size
 Motore

Type Output - Abtrieb
 Sortie - Uscita

Item Pos.	Quant. Menge	Standards Normen Normes Norme	DESCRIPTION	BENENNUNG	DESIGNATION	DENOMINAZIONE	Code
			Input	Eingang	Entrée	Entrata PAM	
			Motor size 132	Baugröße 132	Bride moteur 132	Grandezza motore 132	
29	1		Input flange	Eingangsfansch	Bride entrée	Flangia entrata	20924141A
9	1		Hollow shaft	Hohlwelle	Embout entrée	Boccola entrata	20970461A
	6	DIN 912	Hexagon socket bolt	Innensechskantschraube	V/vis	Vite T.C.E.I.	(M10x50)
	4	DIN 912	Hexagon socket bolt	Innensechskantschraube	V/vis	Vite T.C.E.I.	(M10x30)
	4	DIN 125A	Washer	Unterlegscheibe	Rondelle	Rondella	(M10)
	4	DIN 127B	Elastic washer	Elastische Scheibe	Rondelle élastique	Rondella elastica	(M10)
			Input gear	Radsatz Eingangsseite	Engrenages d'entrée	Sottogruppo coppia entrata	10752830A
			Ratio 1/40	Untersetzung 1:40	Réduction 1:40	Rapporto riduttore 1:40	
18	1		Pinion	Ritzel	Pignon	Pignone	
19	1		Gear wheel	Zahnrad	Roue dentée	Corona	
22	1	DIN 6885	Parallel key	Passfeder	Clavette	Linguetta	(12x8x32)
			Output A 6	Ausgang A 6	Sortie A 6	Uscita A 6	
30	1		Output flange	Ausgangsfansch	Bride sortie	Flangia uscita	20924181A
25	1		Output shaft	Abtriebswelle	Arbre sortie	Albero uscita	20947691A
	4	DIN 933	Hexagon bolt	Sechskantschraube	VHT	Vite T.E.	(M10x150)
	1	DIN 934	Hexagon nut	Sechskantmutter	Écrou hexagon	Dado esagonale	(M16)
	4	DIN 933	Hexagon bolt	Sechskantschraube	VHT	Vite T.E..	(M16x45)
	4	DIN 125B	Elastic washer	Elastische Scheibe	Rondelle élastique	Rosetta elastica	(M 10)
	4	DIN 127A	Washer	Scheibe	Rondelle	Rondella bisellata	(M 10)
	1		Felt ring	Filzring	Joint garniture	Anello di feltro	20989281A

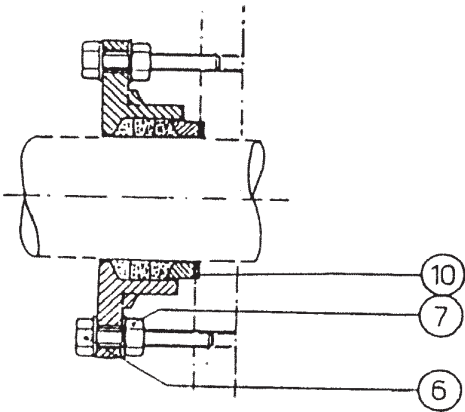
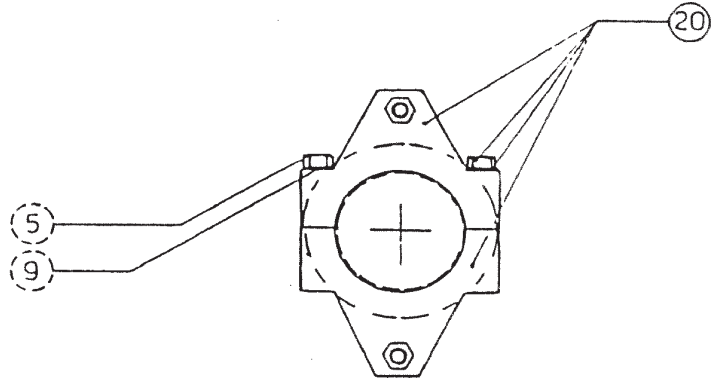
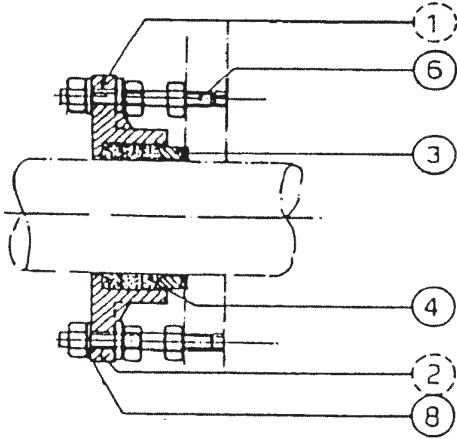

XUC	...	B	1
-----	-----	---	---

030-040-045-050-060-070

Pos.	Quant. Menge	Code XUC030C1	Standards Normen Normes Norme	Description	Benennung	Désignation	Descrizione
20	1	16741861A		Seal cap	Deckel	Couvercle	Coperchio
6	2	20683321B	M8 x 52	Threaded drawbar	Gewindestange	Barre fileté	Barra filettata
3	1	20985281A	Ø 30	Spacer sleeve	Distanzring	Entretoise	Distanziale
4	4*	20988212A		Felt packaging	Brille	Baderne	Baderna
10	1	20991661A		Seal	Dichtung	Garniture	Guarnizione
7	6	2904040040	DIN 934 - M8	Hexagon nut	Sechskantmutter	Ecrou hexagon	Dado esagonale
8	6	2906020050	DIN 125 - A - M8	Wascher	Scheibe	Rondelle	Rosetta
XUC040C1							
20	1	16741881A		Seal cap	Deckel	Couvercle	Coperchio
6	2	20683321B	M8 x 52	Threaded drawbar	Gewindestange	Barre fileté	Barra filettata
3	1	20985301A	Ø 40	Spacer sleeve	Distanzring	Entretoise	Distanziale
4	4*	20988242A		Felt packaging	Brille	Baderne	Baderna
10	1	20991731A		Seal	Dichtung	Garniture	Guarnizione
7	6	2904040040	DIN 934 - M8	Hexagon nut	Sechskantmutter	Ecrou hexagon	Dado esagonale
8	6	2906020050	DIN 125 - A - M8	Wascher	Scheibe	Rondelle	Rosetta
XUC045C1							
20	1	16741891A		Seal cap	Deckel	Couvercle	Coperchio
6	2	20683321B	M8 x 52	Threaded drawbar	Gewindestange	Barre fileté	Barra filettata
3	1	20985311A	Ø 45	Spacer sleeve	Distanzring	Entretoise	Distanziale
4	4*	20988282A		Felt packaging	Brille	Baderne	Baderna
10	1	20991061A		Seal	Dichtung	Garniture	Guarnizione
7	6	2904040040	DIN 934 - M8	Hexagon nut	Sechskantmutter	Ecrou hexagon	Dado esagonale
8	6	2906020050	DIN 125 - A - M8	Wascher	Scheibe	Rondelle	Rosetta
XUC050C1							
20	1	16741901A		Seal cap	Deckel	Couvercle	Coperchio
6	2	20683331B	M10 x 85	Threaded drawbar	Gewindestange	Barre fileté	Barra filettata
3	1	20986321A	Ø 50	Spacer sleeve	Distanzring	Entretoise	Distanziale
4	4*	20988292A		Felt packaging	Brille	Baderne	Baderna
10	1	20991071A		Seal	Dichtung	Garniture	Guarnizione
7	6	2904040050	DIN 934 - M10	Hexagon nut	Sechskantmutter	Ecrou hexagon	Dado esagonale
8	6	2906020060	DIN 125 - A - M10	Wascher	Scheibe	Rondelle	Rosetta
XUC060C1							
20	1	16741921A		Seal cap	Deckel	Couvercle	Coperchio
6	2	20683331B	M10 x 85	Threaded drawbar	Gewindestange	Barre fileté	Barra filettata
3	1	20985341A	Ø 60	Spacer sleeve	Distanzring	Entretoise	Distanziale
4	4*	20988332A		Felt packaging	Brille	Baderne	Baderna
10	1	20991591A		Seal	Dichtung	Garniture	Guarnizione
7	6	2904040050	DIN 934 - M10	Hexagon nut	Sechskantmutter	Ecrou hexagon	Dado esagonale
8	6	2906020060	DIN 125 - A - M10	Wascher	Scheibe	Rondelle	Rosetta
XUC070C1							
20	1	16741931A		Seal cap	Deckel	Couvercle	Coperchio
6	2	20683331B	M10 x 85	Threaded drawbar	Gewindestange	Barre fileté	Barra filettata
3	1	20985351A	Ø 70	Spacer sleeve	Distanzring	Entretoise	Distanziale
4	4*	20988342A		Felt packaging	Brille	Baderne	Baderna
10	1	20991081A		Seal	Dichtung	Garniture	Guarnizione
7	6	2904040050	DIN 934 - M10	Hexagon nut	Sechskantmutter	Ecrou hexagon	Dado esagonale
8	6	2906020060	DIN 125 - A - M10	Wascher	Scheibe	Rondelle	Rosetta

*: for/für
pour/ per XUC03061 N° 3 Felts / Filz / Feutres / Feltri

Seal / Wellenab. Etanch. / Tenuta	For / Für Pour / Per
XUC 030 C1	R 21
XUC 040 C1	R 23
XUC 045 C1	XSP035....
XUC 050 C1	R 25
XUC 060 C1	R 27
XUC 030 C1	XSP055

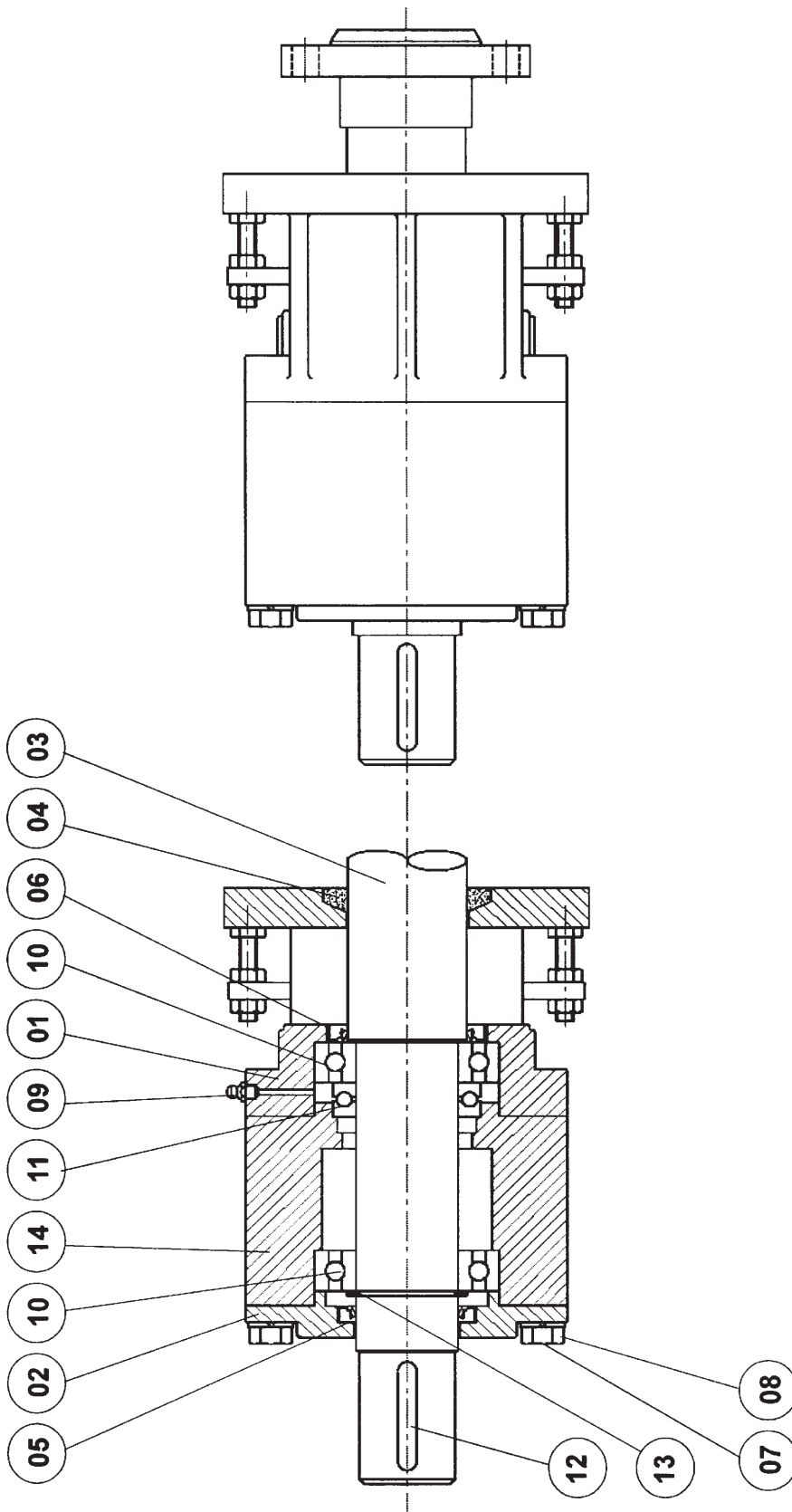

XSV025.**1

Item Pos.	Quant. Menge	Code	Standards Normen Normes Norme	Description	Benennung	Désignation	Descrizione
1	1	20.90.101.1/A		Casing	Gehäuse	Corps	Corpo
2	1	20.90.341.1/A		Cover	Deckel	Couvercle	Coperchio
3	1	20.94.154.1/A		Splined end shaft	Vielkeilwelle	Arbre cannelé	Albero brocciato
4	1	20.98.9251/A		Felt packing	Filzring	Feutre	Feltro
5	1	BA42x30x7		Rotary shaft seal	Wellendichtring	Joint d'étanchéité	Anello tenuta
6	1	BA50x35x8		Rotary shaft seal	Wellendichtring	Joint d'étanchéité	Anello tenuta
7	4	(M 8 x 60)	DIN 588	Hexagonal bolt	Sechskantschr.	VTH	V.T.E.
8	4	(M 8)	DIN 125-A	Washer	Unterlegscheibe	Rondelle	Rosetta
9	1	(B4 M 10 x 1)		Grease nipple	Schmiernippel	Graisser	Ingrassatore
10	1	(6206)(30x62x10)		Bearing	Wälzlager	Roulement	Cuscinetto
11	1		(51106)(30x47x11)	Bearing	Wälzlager	Roulement	Cuscinetto
12	1		8x7x36 DIN6885	Parallel key	Paßfeder	Clavette	Linguetta
13	1		DIN 471 E30	Retaining ring	Seegerring	Seeger	Seeger
14	1	20.90.201.1/A		Casing	Gehäuse	Corps	Corpo

XSV035.**1

Item Pos.	Quant. Menge	Code	Standards Normen Normes Norme	Description	Benennung	Désignation	Descrizione
1	1	20.90.102.1/A		Casing	Gehäuse	Corps	Corpo
2	1	20.90.342.1/A		Cover	Deckel	Couvercle	Coperchio
3	1	20.94.155.1/A		Splined end shaft	Vielkeilwelle	Arbre cannelé	Albero brocciato
4	1	20.98.805.1/A		Felt packing	Filzring	Feutre	Feltro
5	1	BA52x40x7		Rotary shaft seal	Wellendichtring	Joint d'étanchéité	Anello tenuta
6	1	BA60x45x10		Rotary shaft seal	Wellendichtring	Joint d'étanchéité	Anello tenuta
7	4	(M 10 x 25)	DIN 588	Hexagonal bolt	Sechskantschr.	VTH	V.T.E.
8	4	(M 10)	DIN 125-A	Washer	Unterlegscheibe	Rondelle	Rosetta
9	1	(B4 M 10 x 1)		Grease nipple	Schmiernippel	Graisser	Ingrassatore
10	1	(6208)(40x80x18)		Bearing	Wälzlager	Roulement	Cuscinetto
11	1		(51108)(40x60x13)	Bearing	Wälzlager	Roulement	Cuscinetto
12	1		10x8x50 DIN6885	Parallel key	Paßfeder	Clavette	Linguetta
13	1		DIN 471 E40	Retaining ring	Seegerring	Seeger	Seeger
14	1	20.90.202.1/A		Casing	Gehäuse	Corps	Corpo

XSV045.**1

Item Pos.	Quant. Menge	Code	Standards Normen Normes Norme	Description	Benennung	Désignation	Descrizione
1	1	20.90.103.1/A		Casing	Gehäuse	Corps	Corpo
2	1	20.90.343.1/A		Cover	Deckel	Couvercle	Coperchio
3	1	20.94.156.1/A		Splined end shaft	Vielkeilwelle	Arbre cannelé	Albero brocciato
4	1	20.98.949.1/A		Felt packing	Filzring	Feutre	Feltro
5	1	BA5L 65x50x8		Rotary shaft seal	Wellendichtring	Joint d'étanchéité	Anello tenuta
6	1	BA72x55x10		Rotary shaft seal	Wellendichtring	Joint d'étanchéité	Anello tenuta
7	4	(M 10 x 30)	DIN 588	Hexagonal bolt	Sechskantschr.	VTH	V.T.E.
8	4	(M 10)	DIN 125-A	Washer	Unterlegscheibe	Rondelle	Rosetta
9	1	(B4 M 10 x 1)		Grease nipple	Schmiernippel	Graisser	Ingrassatore
10	1	(6210)(50x30x20)		Bearing	Wälzlager	Roulement	Cuscinetto
11	1		(51110)(50x70x14)	Bearing	Wälzlager	Roulement	Cuscinetto
12	1		10x8x50 DIN6885	Parallel key	Paßfeder	Clavette	Linguetta
13	1		DIN 471 E50	Retaining ring	Seegerring	Seeger	Seeger
14	1	20.90.203.1/A		Casing	Gehäuse	Corps	Corpo

XSV055..*1

Item Pos.	Quant. Menge	Code	Standards Normen Normes Norme	Description	Benennung	Désignation	Descrizione
1	1	20.90.104.1/A		Casing	Gehäuse	Corps	Corpo
2	1	20.90.344.1/A		Cover	Deckel	Couvercle	Coperchio
3	1	20.94.157.1/A		Splined end shaft	Vielkeilwelle	Arbre cannelé	Albero brocciato
4	1	20.98.810.1/A		Felt packing	Filzring	Feutre	Feltro
5	1	BA80x60x10		Rotary shaft seal	Wellendichtring	Joint d'étanchéité	Anello tenuta
6	1	BA90x70x10		Rotary shaft seal	Wellendichtring	Joint d'étanchéité	Anello tenuta
7	4	(M 12 x 35)	DIN 588	Hexagonal bolt	Sechskantschr.	VTH	V.T.E.
8	4	(M 12)	DIN 125-A	Washer	Unterlegscheibe	Rondelle	Rosetta
9	1	(B4 M 10 x 1)		Grease nipple	Schmiernippel	Graisseur	Ingrassatore
10	1	(6212)(60x110x22)		Bearing	Wälzlager	Roulement	Cuscinetto
11	1		51112-60x85x17	Bearing	Wälzlager	Roulement	Cuscinetto
12	1		10x8x50 DIN6885	Parallel key	Paßfeder	Clavette	Linguetta
13	1		DIN 471 E60	Retaining ring	Seegerring	Seeger	Seeger
14	1	20.90.204.1/A		Casing	Gehäuse	Corps	Corpo

XSV065..*1

Item Pos.	Quant. Menge	Code	Standards Normen Normes Norme	Description	Benennung	Désignation	Descrizione
1	1	20.90.105.1/A		Casing	Gehäuse	Corps	Corpo
2	1	20.90.345.1/A		Cover	Deckel	Couvercle	Coperchio
3	1	20.94.158.1/A		Splined end shaft	Vielkeilwelle	Arbre cannelé	Albero brocciato
4	1	20.98.930.1/A		Felt packing	Filzring	Feutre	Feltro
5	1	BASL90x70x10		Rotary shaft seal	Wellendichtring	Joint d'étanchéité	Anello tenuta
6	1	BA100x80x10		Rotary shaft seal	Wellendichtring	Joint d'étanchéité	Anello tenuta
7	4		DIN 588	Hexagonal bolt	Sechskantschr.	VTH	V.T.E.
8	4		DIN 125-A	Washer	Unterlegscheibe	Rondelle	Rosetta
9	1	(B4 M 10 x 1)		Grease nipple	Schmiernippel	Graisseur	Ingrassatore
10	1	(6214)(70x125x24)		Bearing	Wälzlager	Roulement	Cuscinetto
11	1		(51114)(70x95x18)	Bearing	Wälzlager	Roulement	Cuscinetto
12	1		10x8x50 DIN6885	Parallel key	Paßfeder	Clavette	Linguetta
13	1		DIN 471 E70	Retaining ring	Seegerring	Seeger	Seeger
14	1	20.90.205.1/A		Casing	Gehäuse	Corps	Corpo

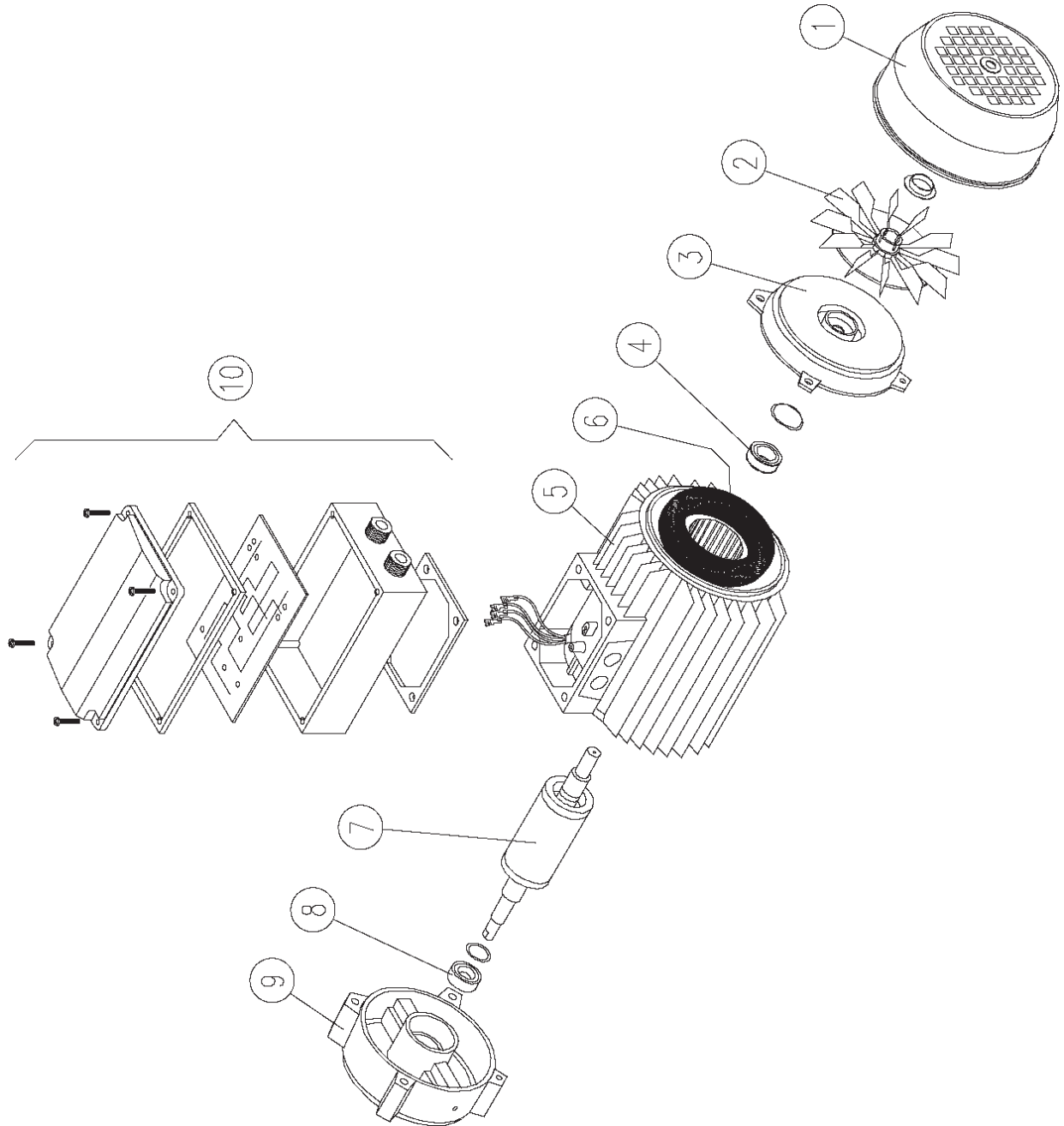

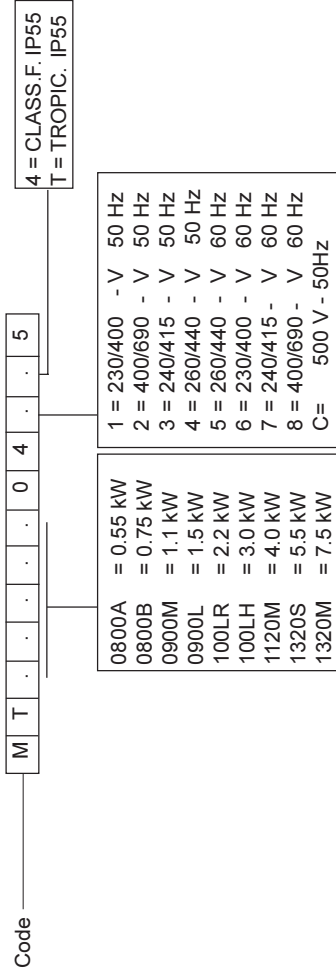

Item Pos. Pos. Pos.	Quant. Menge Quant. Quant.	Standards Normen Normes Norme	DESCRIPTION	BENENNUNG	DESIGNATION	DENOMINAZIONE
1	1		Fan guard	Lüfterhaube	Carter	Copriventola
2	1		Fan	Lüfterflügel	Ventilateur	Ventola
3	1		Rear flange	Hinterer Flansch	Flasque postérieure	Calotta posteriore
4	1		Fan bearing	Lager	Roulement ventilateur	Cuscinetto posteriore
5	1		Casing	Lager Lüfterseite	Corps	Carcassa esterna
6	1		Stator	Ständer	Stator	Statore
7	1		Rotor	Rotor	Rotor	Rotore
8	1		Front bearing	Vorderes Lager	Roulement antérieur	Cuscinetto anteriore
9	1		Front flange	Vorderer Flansch	Flasque antérieure	Flangia anteriore
10	1		Terminal box	Klemmenkasten	Boîte à bornes	Scatola morsettiara
			European standard motors with 4 poles, B5	IEC-Normmotore 4-polig in Bauform B5	Moteurs à normes européennes à 4 poles B5	Motori a Norme IEC a 4 poli in forma B5

N.B. Rights reserved to modify technical specifications

N.B. Angaben ohne Gewähr. Änderungen können ohne Vorankündigung vorgenommen werden.

N.B. Toutes données portées dans le présent catalogue n'engagent pas le fabricant. Elles peuvent être modifiées à tout moment.

N.B. Tutti i dati riportati nel presente catalogo non sono impegnativi e possono subire variazioni in qualsiasi momento.



WAM®

WAM S.p.A.
Via Cavour, 338
I - 41030 Ponte Motta
Cavezzo (MO) - ITALY

 +39 / 0535 / 618111

fax +39 / 0535 / 618226

e-mail info@wamgroup.it

internet www.wamgroup.com

videoconference + 39 / 0535 / 49032