



WAM®



1

TECHNICAL CATALOGUE

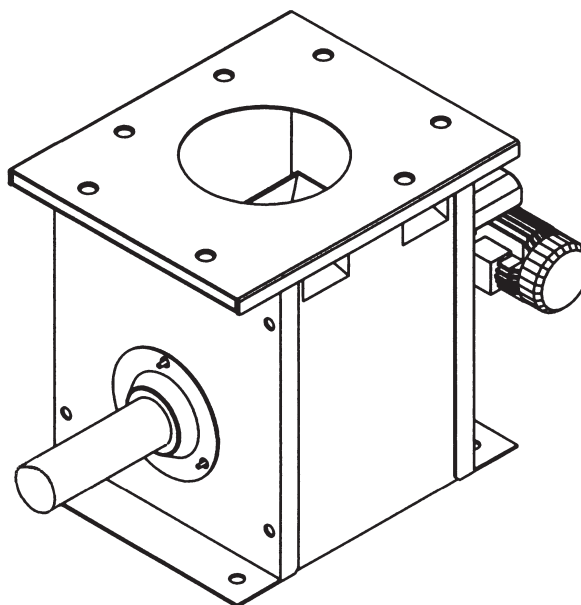

MBF

- **MICRO - BATCH FEEDERS**
TECHNICAL CATALOGUE
- **MIKRODOSIERER**
TECHNISCHER KATALOG
- **MICRODOSEURS**
CATALOGUE TECHNIQUE
- **MICRODOSATORI**
CATALOGO TECNICO

All rights reserved © WAMGROUP

CATALOGUE No.		WA.02515 T.	CREATION DATE
ISSUE	CIRCULATION	DATE OF LATEST UPDATE	03.00
A15	100	08.07	



WAM®

All the products described in this catalogue are manufactured according to **WAM® S.p.A. Quality System procedures.**

The Company's Quality System, certified in July 1994 according to International Standards **UNI EN ISO 9002-94** and extended to **UNI EN ISO 9001-2000** in October, 2002, ensures that the entire production process, starting from the processing of the order to the technical service after delivery, is carried out in a controlled manner that guarantees the quality standard of the product.

*Alle in diesem Katalog beschriebenen Erzeugnisse werden in Konformität mit dem **Qualitätssystem der WAM® S.p.A. hergestellt.***

*Das im Juli 1994 zertifizierte Qualitätssystem entspricht der Norm **UNI EN ISO 9002-94** (im Oktober 2002 auf **UNI EN ISO 9001-2000** erweitert) und gewährleistet dem Kunden eine strenge Qualitätskontrolle in jeder Phase des Produktionsprozesses bis hin zum Kundendienst nach Auslieferung der Ware.*

Tous les produits décrits dans ce catalogue ont été réalisés selon les modalités opérationnelles définies **Système de Qualité de WAM® S.p.A.**

Le système de Qualité de l'entreprise, certifié au mois de juillet 1994 en conformité aux Normes Internationales **UNI EN ISO 9002-94** et successivement étendu à **UNI EN ISO 9001-2000** au mois de octobre 2002, est en mesure d'assurer que le procédé entier de production, à partir de la formulation de la commande jusqu'au service technique après la livraison, soit effectué de manière contrôlée et appropriée afin de garantir le standard de qualité du produit.

*Tutti i prodotti descritti in questo catalogo sono stati realizzati secondo modalità operative definite **Sistema Qualità di WAM® S.p.A.***

*Il Sistema Qualità aziendale, certificato dal luglio 1994 in conformità alle Normative Internazionali **UNI EN ISO 9002-94** e successivamente esteso alle Normative Internazionali **UNI EN ISO 9001-2000** nell'ottobre 2002, è in grado di assicurare che l'intero processo produttivo, dalla formulazione dell'ordine fino all'assistenza tecnica successiva alla consegna, venga effettuato in modo controllato ed adeguato a garantire lo standard qualitativo del prodotto.*



**UNI EN ISO 9001-2000
Certified Company**

**This publication cancels and replaces any previous edition and revision.
We reserve the right to implement modifications without notice.
This catalogue cannot be reproduced, even partially, without prior consent.**

***Diese Veröffentlichung annulliert und ersetzt jeder hergehende Edition oder Revision.
WAM® behält sich das Recht vor, Änderungen ohne vorherige Informationen durchzuführen.***

**Cette publication annule et remplace toutes les autres précédentes.
Nous nous réservons le droit d'apporter toutes modifications à nos produits.
La reproduction et la publication partielle ou totale de ce catalogue est interdite sans notre autorisation.**

***Questa pubblicazione annulla e sostituisce ogni precedente edizione o revisione.
Ci riserviamo il diritto di apportare modifiche senza preavviso.
E' vietata la riproduzione anche parziale senza autorizzazione.***

1 TECHNICAL CATALOGUE

DESCRIPTION AND TECHNICAL CHARACTERISTICS.....

ORDER CODES.....

ACCESSORIES.....

OPERATION AND MAINTENANCE.....

INQUIRY AND ORDER FORM.....

TECHNISCHER KATALOG

BESCHREIBUNG UND TECHNISCHE MERKMALE..... **I. 6 → .23**

BESTELLCODES..... **24 → .27**

ZUBEHÖR..... **28 → .42**

BETRIEBS- UND WARTUNGSANLEITUNG..... **43**

ANFRAGE- UND BESTELLBLATT..... **44**

1 CATALOGUE TECHNIQUE

DESCRIPTION ET CARACTERISTIQUES TECHNIQUES

CODES DE COMMANDE.....

ACCESSOIRES.....

UTILISATION ET ENTRETIEN.....

QUESTIONNAIRE.....

CATALOGO TECNICO

DESCRIZIONE E CARATTERISTICHE TECNICHE..... **T. 6 → .23**

CODICI DI ORDINAZIONE..... **24 → .27**

ACCESSORI..... **28 → .42**

USO E MANUTENZIONE..... **43**

MODULO DI RICHIESTA..... **44**

2 MAINTENANCE CATALOGUE

OPERATION AND MAINTENANCE.....

WARTUNGSKATALOG

BETRIEBS- UND WARTUNGSANLEITUNG..... **M. 4 → .24**

2 CATALOGUE D'ENTRETIEN

UTILISATION ET ENTRETIEN.....

CATALOGO DI MANUTENZIONE

USO E MANUTENZIONE..... **M. 4 → .24**

3 SPARE PARTS CATALOGUE

SPARE PARTS.....

ERSATZTEILKATALOG

ERSATZTEIL..... **R. 4 → .12**

3 CATALOGUE PIECES DE RECHANGE

PIECES DE RECHANGE.....

CATALOGO RICAMBI

PEZZI DI RICAMBIO..... **R. 4 → .12**

CODES - CODEBEZEICHNUNGEN - SIGLES - SIGLE

MBF	Micro batch feeder	Mikrodosierer	Microdoseur modulaire	Microdosatore per polveri
MDXCR	Round cover	Runde Abdeckung	Couvercle rond	Coperchio tondo
MDXGS	Cutter grille for square hopper	Quadratischer Aufreißgrill	Grille carré	Griglia quadrata
MDXSV	Vertical spout	Ablaufrohr	Sortie verticale	Scarico verticale
MDXTR	Round hopper	Runder Aufgabetrichter	Trémie ronde	Tramoggia verticale
MDXTS	Square hopper	Quadratischer Aufgabetrichter	Trémie carrée	Tramoggia quadrata
UTD	Metering screw	Dosierwerkzeug	Outil dosage	Utensile dosaggio
UTO	Blending tool	Homogenisierwerkzeug	Homogénéisateur	Utensile omogenizzazione
MBT	Seal	Wellenabdichtung	Etanchéité	Tenuta
MBTP	Extendend pipe	Verlängert Innenrohr	Tube rallongé	Tubo prolungato
MBPR	Linerfeeder pipe	Dosierrohr mit innernaikleidung	Tube de dosage avec revêtement interieur	Scarico rivestito internamente
MBPI	STD inspection hatch	STD inspektionstür	Trappe de visite	Portello di ispezione
MBPIP	Inspection hatch with extended tube	Inspektionstür mit länglichrohr	Trappe de visite avec tube prolonge	Portello di ispezione con tubo prolungato

MBF micro-batch feeders are used in gravimetric and volumetric dosing plants for powders and granular materials of various kinds. The body is made of WAM's engineering polymers SINT[®]ER, SINT[®]AL or AISI 304L/316L, while all other feeder parts including nuts and bolts are made of stainless steel 304.

On request micro-batch feeders are supplied in a food-grade version.

Unless otherwise specified, all the dimensions are given in millimetres.

MBF Mikrodosierer werden in gravimetrischen und volumetrischen Dosieranlagen für Schüttgüter aller Art eingesetzt. Das Gehäuse besteht aus den Polymeren SINT[®]ER, SINT[®]AL oder edelstahl 1.4301/1.4401. Alle anderen Komponenten einschließlich Schraubenmaterial sind aus Edelstahl 1.4301.

Auf Wunsch ist eine nahrungsmitteltaugliche Version lieferbar.

Wenn nicht anders angegeben, alle Maßangaben in Millimetern.

Les microdoseurs MBF sont utilisés dans toutes les installations de dosage à poids ou volumétriques. Le corps est construit en SINT[®]ER, SINT[®]AL ou AISI 304L/316L. Les autres composants sont en acier inox 304L, boulonnerie comprise.

Sur demande le microdoseur est fourni en version indiquée pour des produits alimentaires.

Sauf indication contraire, toutes les dimensions sont exprimées en millimètres.

I microdosatori MBF sono utilizzati in tutti gli impianti di dosaggio a peso o volumetrici. Il corpo è costruito in SINT[®]ER, SINT[®]AL o AISI 304L/316L, mentre le altre parti sono in AISI 304L, bulloneria compresa.

Su richiesta, queste macchine possono essere fornite idonee per prodotti alimentari.

Se non specificato altrimenti, tutte le dimensioni sono in millimetri.

FINISHING - FINISH - FINITION - FINITURE

End plate	Endschild	Bride d'extrémité	Frontale	AISI 304L EDELSTAHL 1.4301
Drive support	Antriebshaltung	Plaque de fixation	Piastra d'attacco	ALUMINIUM ALLUMINIO
Reducer	Getriebe	Reducteur	Riduttore	ALUMINIUM ALLUMINIO
Speed variator	Regelgetriebe	Variateur	Variatore	RAL 5010
Motor	Elektromotor	Moteur	Motore	RAL7001

SELECTION CRITERIA - AUSWAHLKRITEREN - CRITERES DE CHOIX - CRITERI DI SCELTA

CF = [dm³/ J] = theoretical capacity per hour at 1 RPM.
CE = [dm³/ h] = real capacity of MBF
CR = [dm³/ h] requested capacity.
CT = [dm³/ h] theoretical capacity
N = [RPM] = metering screw speed.
mvs = material efficiency

Given:

- the characteristics of the material to be handled, the application and the feeding system into the microbatch feeder;
- CR (=capacity requested by customer), in order to choose correct MBF type proceed as follows:
- Check from material table mvs and all other important characteristics (e.g. metering screw type, accessories, others)
- Calculate real capacity CE of standard MBF (with fixed or variable speed as required by customer)

$$CE = CT \times mvs$$

where for CT refer to page T.10. If difference between CE and CT is too big (that is, if customer does not accept standard MBF) it is necessary to find correct MBF speed in order to obtain the requested capacity, using the following formula:

$$N = \frac{CR}{CF \times mvs}$$

Subsequently, select ratio nearest to specific requirements (see page T.11). In carrying out these calculations it has to be born in mind that mvs given in materials table is empirical. The real value depends on a number of factors which may be difficult to control, such as the condition of the material, atmospheric conditions, height of material column inside the hopper, speed of rotation etc. For material efficiency mvs see pag. T10.

CF = [dm³/J] = theoretische Stundenleistung bei 1 U/min
CE = [dm³/ h] = effektive Dosierleistung MBF
CR = [dm³/ h] = kundenseits geforderte Dosierleistung
CT = [dm³/ h] = theoretische Dosierleistung
N = [Upm] = Drehzahl des Dosierwerkzeugs
mvs = Material-Wirkungsgrad

Gegeben:

- Bezeichnung und Beschreibung des Dosierguts, zu erwartende Betriebs- und Beschickungsart
- CR (= kundenseits geforderte Dosierleistung). Um den MBF-Dosierer korrekt auszulegen, muß nun wie folgt vorgegangen werden:
- Eigenschaften des Dosierguts der Materialtabelle entnehmen z.B. mvs, Dosierwerkzeug, Zubehör etc.)
- Effektive Dosierleistung CE des Standard-Dosierers errechnen (mit fester oder variabler Drehzahl, je nach Kundenwunsch)

$$CE = CT \times mvs$$

wobei CT wie auf Seite T.10 angegeben. Wenn Differenz zwischen GE und CT zu groß, bzw. Kunde MBF Standard-Dosierer nicht akzeptiert, muß jene Drehzahl gefunden werden, bei welcher der Dosierer die kundenseits geforderte Stundenleistung erbringt. Hierzu ist folgende Formel zu verwenden :

$$N = \frac{CR}{CF \times mvs}$$

Demzufolge wählt man eine Getriebeuntersetzung (siehe Seite T.11), die den Wünschen des Kunden am nächsten kommt. Bei der Ermittlung der vorgenannten Werte ist zu berücksichtigen, daß der in der Materialtabelle aufgeführte Parameter mvs ein rein empirischer Durchschnittswert aus der Summe der bisher gemachten Erfahrungen mit dem jeweiligen Medium ist, welcher im Einzelfall teilweise stark schwankt. In der Tat hängt mvs von mehreren, zum Teil schwer kontrollierbaren Variablen ab (z.B. Zustand des Dosierguts, Witterungseinflüsse, Materialsäule im Aufgabetrichter, Dosierer-Drehzahl etc.). Für Material-Wirkungsgrad siehe Seite T.10.

CF = [dm³/J] = débit horaire théorique pour 1 RPM
CE = [dm³/h] = débit effectif MBF
CR = [dm³/h] débit souhaité par le client
CT = [dm³/h] débit théorique MBF
N = [TPM] = vitesse de rotation de la spire doseuse.
mvs = coefficient du matériau

Donné:

- la description du matériau à doser, le fonctionnement prévu et le système d'alimentation du microdoseur,
- CR (= débit souhaité par le client), là succession correcte des opérations pour la choix d'un microdoseur est la suivante:
- Contrôler dans le tableau des matériaux mvs et toutes les autres caractéristiques importantes (ex.: type de spire doseuse, accessoires, autres) - Calculer le débit effectif CE du MBF standard (vitesse fixe ou variable suivant la demande du client)

$$CE = CT \times mvs$$

où CT est à la page T.10. Si la différence entre CE et CT est trop grande (c'est à dire, le client n'accepte pas le MBF standard), il est nécessaire de trouver à quelle vitesse de rotation devra tourner le MBF pour obtenir le débit souhaité par le client. On utilisera la formule:

$$N = \frac{CR}{CF \times mvs}$$

Ensuite il faut choisir (voir page T.11) le rapport qui se rapproche le plus de celui souhaité par le client. A ce point du calcul quoi qu'il en soit, il est nécessaire de tenir compte que mvs figurant dans le tableau matériaux est en réalité une donnée empirique obtenue comme une moyenne des résultats de l'expérience passée. Cette donnée peut dépendre en fait de multiples facteurs difficiles à contrôler (ex. état du matériau, conditions atmosphériques, hauteur de la colonne du matériau dans la trémie, vitesse de rotation etc.). Le coefficient du matériau mvs est indiqué a page T.10.

CF = [dm³/J] = portata teorica oraria per 1 RPM
CE = [dm³/h] = portata effettiva MBF
CR = [dm³/h] = portata richiesta dal cliente
CT = [dm³/h] = portata teorica MBF
N = [RPM] = velocità di rotazione dell'utensile di dosaggio
mvs = efficienza del materiale

Dati:

- la descrizione dei materiale da dosare, il funzionamento previsto e il sistema di alimentazione dei microdosatore,
- CR (= portata richiesta dal cliente), la successione corretta delle operazioni per la scelta dei MBF è la seguente:
- controllare mvs e tutte le altre caratteristiche importanti nella tabella materiali (es.: tipo di utensile di dosaggio, accessori, vari, etc.)
- calcolare la portata effettiva CE del MBF standard (a velocità fissa o variabile in base alla richiesta dei cliente)

$$CE = CT \times mvs$$

dove CT è a pag. T.10. Se la differenza tra CE e CT è troppo grande (cioè il cliente non accetta il ns. MBF standard) è necessario trovare a quale velocità di rotazione deve ruotare l' MBF per ottenere la portata richiesta dal cliente. Si usa la formula:

$$N = \frac{CR}{CF \times mvs}$$

Poi si sceglie (vedi pag. T.11) il rapporto che più si avvicina ai desideri del cliente. In questi calcoli è comunque necessario tenere presente che mvs riportato nella tabella materiali, è in realtà un dato empirico ottenuto come media dei risultati delle esperienze fatte, risultati talvolta anche distanti tra di loro. Esso può dipendere infatti da molteplici variabili, alcuni delle quali di difficile controllo (es. stato del materiale, condizioni atmosferiche, altezza colonna materiale nella tramoggia, velocità di rotazione, etc.). Il coefficiente mvs è indicato a pagina T.10.

STANDARD SUPPLY - STANDARD-LIEFERUMFANG - FORNITURE STANDARD - FORNITURE STANDARD

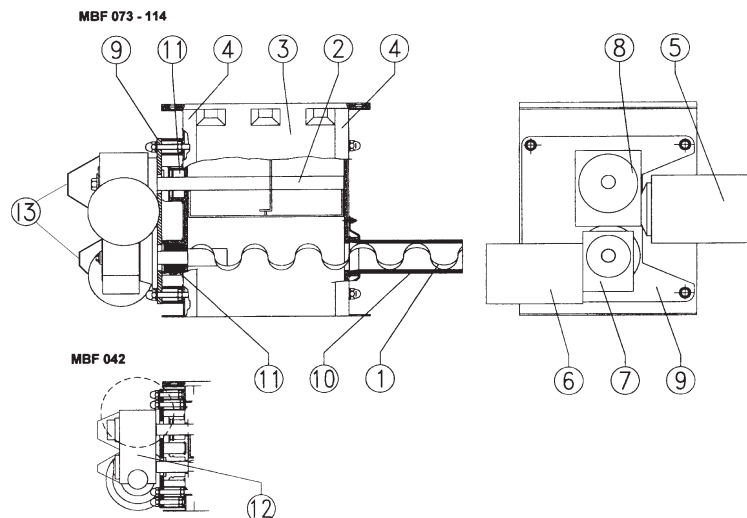

1	Metering screw	Dosierwerkzeug	Vis de dosage	Utensile dosaggio
2	Blending tool	Homogenisierwerkzeug	Homogénéisateur	Utensile omogeneiz.
3	Elastomer trough	Dosiertrog	Corps	Corpo
4	End plate	Endschild	Bride d'extrémité	Frontale
5	Agitator motor	E- Motor Homogenisierer	Moteur electr. outil de homogé.	Motore elect. omogen.
6	Metering screw motor	E- Motor Dosierer	Moteur elect. outil de dosage	Motore elect. dosaggio
7	Metering screw reducer	Getriebe Dosierer	Réducteur outil de dosage	Riduttore dosaggio
8	Blending tool reducer	Getriebe Homogenisierer	Réducteur outil de homogén.	Riduttore omogeneiz.
9	Drive support	Antriebshalterung	Plaque de fixation	Piastra d'attacco
10	Feeder pipe	Dosierrohr	Sortie	Uscita
11	Seals	Wellenabdichtungen	Etanchéités	Tenute
12	Reducer	Getriebe	Réducteur	Riduttore
13	Cover	Abdeckung	Couvercle	Coperchio

N.B. Item 4 in the stainless steel version, front panel can be opened for inspection.

N.B. Pos.4 in der Edelstahlversion mit abnehmbarer Frontplatte zu Inspektionszwecken.

N.B. Pos.4 dans la version en acier inox, plaque frontale peut être ouverte pour inspection.

N.B. Pos.4 nella versione in AISI, frontale apribile per ispezione.

The batch feeder must not be started before the screw conveyor itself, as well as the plant it is going to be installed in, have been declared in conformity with the European Directive 14/06/1982 (89/392/EEC).

It is the plant designer's / plant fitter's responsibility to design and install all necessary protection in order to avoid that breaking and / or yielding of the equipment or of parts of it might damage people and / or parts of the plant (e.g. adequate protection against falling down of the motor etc.).

For dangerous materials, i.e. those that must not get in contact with the human body or be inhaled, for flammable, explosive and bacteriologically dangerous materials the plant manufacturer or fitter must provide for the required safety devices and measures.

Der Dosier darf nicht in Betrieb genommen werden, bevor sowohl sie selbst, als auch die Anlage, in die sie eingebaut wird, mit den Vorschriften der Direktive 14/06/1982 (89/392/ECC) für konform erklärt wurde.

Es liegt in der Verantwortung des Anlagenplaners bzw. -aufstellers, alle notwendigen Schutzvorrichtungen vorzusehen, welche es verhindern, daß durch einen Geräte- oder Teiledefekt Personen- und/oder Sachschäden verursacht werden (z.B. geeigneter Schutz gegen das Herunterfallen des Motors etc.).

Für Gefahrenprodukte, bzw. solche, die nicht mit dem menschlichen Körper in Kontakt geraten oder eingeatmet werden dürfen, für leicht entzündbare, explosive sowie bakteriologisch gefährliche Medien muß der Anlagenbauer bzw. -erichter die für die Sicherheit erforderlichen Vorrichtungen vorsehen und Maßnahmen treffen.

Il est interdit de mettre le doseur en fonction avant que la machine / l'installation dans laquelle elles doivent être montées a été déclarée conforme aux dispositions de la Directive 14/06/1982 (89/392/EEC).

Dans ce cadre il est la responsabilité du constructeur de l'installation ou de l'installateur de projeter et d'installer tout équipement de protection nécessaire afin d'éviter que des ruptures et / ou des parties d'elle puissent causer de dégâts à des personnes et / ou des choses (par ex.: des protections appropriées contre la chute du moteur etc.).

Pour des produits dangereux, nuisibles au contact et/ou à l'inhalation, inflammables, explosifs et dangereux du point de vue bactériologique et/ou viral, le constructeur de l'installation ou l'installateur devront prévoir des dispositifs appropriés au besoin.

E' vietato mettere il dosatore in funzione prima che la macchina/impianto, nel quale devono essere installate, sia dichiarato conforme alle disposizioni della direttiva 14/06/1982 (89/392/EEC).

In quest'ambito è cura dell'impiantista / installatore predisporre ed installare tutti gli accorgimenti / protezioni al fine di evitare danni a cose o persone in caso di rotture e conseguente caduta di pezzi della macchina (ad es.: rottura del motore). Per prodotti pericolosi, nocivi al contatto e/o all'inalazione, infiammabili, esplosivi e pericolosi dal punto di vista batteriologico e/o virale, l'impiantista e/o l'installatore, dovranno prevedere idonei dispositivi all'uopo.

THEORETICAL STANDARD FEED RATES - THEORETISCHE STANDARD - DOSIERLEISTUNGEN
DEBITS THEORIQUES STANDARD - PORTATE TEORICHE STANDARD



TAB. 1

MBF		THEORETICAL STANDARD FEED RATES THEORETISCHE STANDARD-DOSIERLEISTUNGEN DEBITS THEORIQUES STANDARD PORTATE TEORICHE STANDARD				CT
Metering screws Dosierwerkzeuge Outils dosage Utensili dosatori	Hourly feed rate at Dosierleistung pro Stunde bei Débit horaire à Portata oraria a	Fixed speed feed rate Leistung bei Konstanter Drehzahl Débit à vitesse fixe Portata a velocità fissa	Feed rate with variable speed Leistung bei variabler Drehzahl Débit à vitesse variable Portata a velocità variabile	Capacity whit diff. variator Leist. bei var. Drehz. + Diff. Débit à vites. var. avec différ. Port.a vel. variab. con differ.		
	1 rpm	93 rpm	13 - 67 rpm	4 - 60 rpm		
Type	dm ³ / h	dm ³ / h	dm ³ / h	dm ³ / h		
042	1 - 4 - D	0.7	65	9 - 48		
	3	0.6	56	8 - 40		
	5	0.64	60	8 - 45		
	7	0.95	88	12 - 64		
073	1 - 2 - B	5.7	530	74 - 382	23 - 342	
	3	4.4	410	57 - 295	18 - 264	
	4 - 5 - D - E	7.4	777	105 - 555	31 - 421	
114	1 - 2 - B	26	2418	338 - 1742	104 - 1560	
	3	13.6	1265	177 - 911	55 - 816	
	4 - 5 - D - E	29.7	3800	423 - 2230	130 - 1930	

N.B. The theoretical feed rate has to be multiplied by the efficient factor which depends on the type of feeder screw and on the material fed.
 N.B. Die theoretische Dosierleistung ist dem Wirkungsfactor zu multiplizieren, der wiederum abhängig ist vom Dosierwendeltyp und vom dosierten Medium.
 N.B. Le débit théorique doit être multiplié par le facteurs d'efficience qui est en fonction de la spire et du produit dosé.
 N.B. La portata teorica deve essere moltiplicata per il fattore di efficienza che è in funzione dell'elica e del prodotto trasportato.

General efficiency coefficient mvs depeneding on feeder screw used
Allgemeiner Wirkungsgrad mvs in Abhängigkeit von der eingesetzten Dosierwendel
Coefficient d'efficacit  g n ral en fonction du type de spire utilis e
Coefficienti di efficienza generico mvs, in funzione del tipo di elica utilizzata

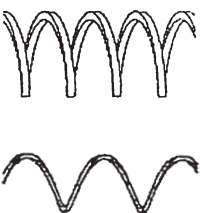
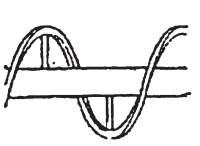
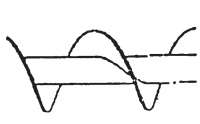
TAB. 3

UTD. 12 UTD. 32	UTD. 22 UTD. B2	UTD. 42 UTD. D2	UTD. 5 UTD. G UTD. E
			
Efficiency: 1.1	Wirkungsgrad: 0.6	Coefficient: 0.75	Efficienza: 0.7

The theoretical feeds rate (pag.T.11)has to be multiplied by the efficient factor which depends on the type of feeder screw fed.

Note:

The efficiency factor can vary due to grain size, bulk density, degree of humidity and all the other material properties that have an influence on handling the material.

Die theoretischen Dosierleistungen gem. Seite T.11 m ssen mit diesem Faktor je nach eingesetzter Dosierwendeltype multipliziert werden.

Anm.:

Der Wirkungsgrad kann sich aufgrund der K rnung, des Sch ttgewichts, des Feuchtegrads sowie aller  brigen, sich auf das Handling auswirkenden Produkte.

Les d bits th oriques comme   page T.11 doivent  tre multipli s par ce facteur en fonction des spires choisies.

Note:

Le facteur d'efficacit  peut subir des variations   cause de la granulom trie, du poids sp cifique, de l'humidit  et de tous les composants imputables au mat riau transport .

Le portate teoriche come a pag. T.11 debbono essere moltiplicate per questo fattore in funzione delle eliche scelte.

Nota:

Il fattore di efficienza pu  subire delle variazioni dovute a granulometria, al peso specifico, umidit  e a tutte quelle componenti imputabili al prodotto trasportato.

THEORETICAL CAPACITIES SPC - THEORETISCHE DOSIERLEIST.SPEZ.
DEBITS THEORIQUES SPC. - PORTATE TEORICHE SPECIALI

TAB. 2

MBF				THEORETICAL FEED RATES THEORETISCHE DOSIERLEISTUNGEN DEBITS THEORIQUES PORTATE TEORICHE			CT
Metering screws Dosierwerkzeuge Outils dosage Utensili dosatori	Hourly feed rate at Dosierleistung pro Stunde bei Débit horaire à Portata oraria a 1 rpm	Gear ratios Getriebeuntersetzungen Rapports réducteurs Rapporti riduttori	Fixed speed feed rate Leistung bei Konstanter Drehzahl Débit à vitesse fixe Portata a velocità fissa	Feed rate with variable speed Leistung bei variabler Drehzahl Débit à vitesse variable Portata a velocità variabile		Capacity with diff. variator Leist. bei var. Drehz. + Diff. Débit à vites. var. avec différ. Port.a vel. variab. con differ.	
Type	dm ³ / h	1 / ..	dm ³ / h	dm ³ / h MIN	dm ³ / h MAX	dm ³ / h	
042	1-4-D 0.7	10	98	14	70		
		15 (std)	65	9	48		
		28	35	7	25		
		40	24	3.5	17		
3	0.6	10	82	12	60		
		15 (std)	56	8	40		
		28	29	4.3	21		
		40	20	2.6	15		
5	0.64	10	90	13	64		
		15 (std)	60	8	43		
		28	32	4.5	23		
		40	22	3	16		
7	0.95	10	133	18	95		
		15 (std)	88	12	64		
		28	47	6.5	34		
		40	33	4.7	23		
073	1-2-B 5.7	10	798	108	570	34-512	
		15 (std)	530	74	382	23-342	
		20	399	57	285	17-256	
		28	285	40	205	12-183	
	3	4.4	10	616	84	440	27-396
			15 (std)	410	57	295	18-264
			20	308	44	220	14-198
			28	220	31	158	10-141
	4-5-D-E	7.4	10	154	21	111	7-99
			15 (std)	1036	140	740	41-561
			20	688	96	496	31-421
			28	518	74	370	21-282
114	1-2-B 26	10	3640	494	2600	156-2340	
		15 (std)	2418	338	1742	104-1560	
		20	1820	260	1300	78-1170	
		28	1300	181	936	56-836	
	3	13.6	10	910	130	650	39-585
			15 (std)	1904	258	1360	82-1224
			20	1265	177	911	55-816
			28	952	136	680	41-612
	4-5-D-E	29.7	10	680	95	489	29-437
			15 (std)	476	68	340	21-306
			20	4158	564	2970	170-2574
			28	2762	386	1990	130-1930
4-5-D-E	29.7	10	2079	297	1485	85-1287	
		15 (std)	1485	208	1070	68-1029	
		20	1039	149	742	42-642	
		28	1039	149	742	42-642	

N.B. The theoretical feed rate has to be multiplied by the efficient factor which depends on the type of feeder screw and on the material fed.
 (See tab. 3 pag. T.10)

N.B. Die theoretische Dosierleistung ist dem Wirkungsfactor zu multiplizieren, der wiederum abhängig ist vom Dosierwendeltyp und vom dosierten Medium. (Siehe Tabelle 3 Seite T.10)

N.B. La débit théorique doit être multiplié par le facteurs d'efficience qui est en fonction de la spire et du produit dosé. (Voir tab. 3 pag. T.10)

N.B. La portata teorica deve essere moltiplicata per il fattore di efficienza che è in funzione dell'elica e del prodotto trasportato. (vedi tab.3 pag. T.10)

FIXED SPEED DRIVES - ANTRIEBE MIT KONSTANTER DREHZAHL
MOTORIZATIONS A VITESSE FIXE - MOTORIZZAZIONI A VELOCITA' FISSA

METERING SCREW - DOSIERWERKZEUG - OUTIL DOSAGE - UTENSILE DOSAGGIO				
RPM	STANDARD	SPECIAL		
		93	140	50
Ratio - <i>Untersetzung</i> Rapport - <i>Rapporto</i>	1:15	1:10	1:28	1:40
Gear red. - <i>Getriebe</i> Réduct. - <i>Riduttore</i>	RW BB ØØ	RW AA ØØ	RW DA ØØ	RW EA ØØ
Motors - <i>E-Motoren</i> Moteurs - <i>Motori</i>	0.12 kW 4P 50 Hz 63A (std) (0.18 kW 4P 50 Hz 63b)			
BLENDING TOOL - HOMOGENISIERWERKZEUG - OUTIL DE HOMOGENEISATION - OMOGENEIZZATORE				
RPM	35	50		
Ratio - <i>Untersetzung</i> Rapport - <i>Rapporto</i>	1:40	1:28		
Motors - <i>E-Motoren</i> Moteurs - <i>Motori</i>	0.25 kW 4P 50 Hz 71A (std) (0.37 kW 4P 50 Hz 71B)			

METERING SCREW - DOSIERWERKZEUG - OUTIL DOSAGE - UTENSILE DOSAGGIO				
RPM	STANDARD	SPECIAL		
		93	140	70
				35
Ratio - <i>Untersetzung</i> Rapport - <i>Rapporto</i>	1:15	1:10	1:20	1:28
				1:40
Gear red. - <i>Getriebe</i> Réduct. - <i>Riduttore</i>	B5 PAM 71 Ø Flange = 160 mm Ø M* = 14 mm Ø U* = 24 mm			
Motors - <i>E-Motoren</i> Moteurs - <i>Motori</i>	0.25 kW 4P 50 Hz 71A (std) (0.37 kW 4P 50 Hz 71B)			
BLENDING TOOL - HOMOGENISIERWERKZEUG - OUTIL DE HOMOGENEISATION - OMOGENEIZZATORE				
RPM	STANDARD	SPECIAL		
	35	14		
Ratio - <i>Untersetzung</i> Rapport - <i>Rapporto</i>	1:40	1:100		
Gearbox - <i>Getriebe</i> Réduct. - <i>Riduttore</i>	B5bi PAM 80 Ø Flange = 200 mm Ø M* = 19 mm Ø U* = 25 mm			
Motors - <i>E-Motoren</i> Moteurs - <i>Motori</i>	0.55 kW 4P 50 Hz 80A (std) (0.75 kW 4P 50 Hz 80B)			

* ØM = Ø Electric motor shaft - *Welle elektromotore* - Arbre moteur électrique - *Albero motore elettrico*

* ØU = Ø Screw shaft - *Werkzeugwelle* - Arbre outil - *Albero utensile*

**VARIABLE SPEED DRIVES - ANTRIEBE MIT VARIABLEM DREHZAHL
 MOTORISATIONS A VITESSE VARIABLE - MOTORIZZAZIONI A VELOCITA' VARIABILE**

MBF 042	METERING SCREW - DOSIERWERKZEUG - OUTIL DOSAGE - UTENSILE DOSAGGIO				
	RPM	STANDARD	SPECIAL		
		93	140	50	35
Ratio - <i>Untersetzung</i> Rapport - <i>Rapporto</i>	1:15	1:10	1:28	1:40	
Gear red. - <i>Getriebe</i> Réduct. - <i>Riduttore</i>	RW NB ØØ	RW MA ØØ	RW QA ØØ	RW RA ØØ	
Variator - <i>Regelgetr.</i> Variateur - <i>Variatore</i>	B5/B5 PAM 63/63 n° 190-910 rpm Ø Flange 140/140 mm Ø M* = 11 mm Ø U* = 11 mm				
Motors - <i>E-Motoren</i> Moteurs - <i>Motori</i>	0.12 kW 4P 50 Hz 63C B5 (std) (0.18 kW 4P 50 Hz 63C B5)				
BLENDING TOOL - HOMOGENISIERWERKZEUG - OUTIL DE HOMOGENEISATION - OMOGENEIZZATORE					
RPM	35	50			
Ratio - <i>Untersetzung</i> Rapport - <i>Rapporto</i>	1:40	1:28			
Motors - <i>E-Motoren</i> Moteurs - <i>Motori</i>	0.25 kW 4P 50 Hz 71A B5 (std) (0.37 kW 4P 50 Hz 71B)				

N.B.: the motors provided on the speed variator are special and can therefore be 0.22-0.25 kW, depending on the supplier
 Anm.: Die auf dem Drehzahlregler vorhandenen Motoren sind Spezialausführungen und können je nach Hersteller 0,22 -0,25 kW haben
 N.B.: Etant donnée que les moteurs prévus sur variateur sont spéciaux, ils peuvent être de 0.22-0.25 kW, en fonction du fournisseur
 N.B.: i motori previsti su variatore, essendo speciali, potranno essere, 0.22-0.25 kW in funzione del fornitore

MBF 073 114	METERING SCREW - DOSIERWERKZEUG - OUTIL DOSAGE - UTENSILE DOSAGGIO					
	RPM	STANDARD	SPECIAL			
		93	140	70	50	35
Ratio - <i>Untersetzung</i> Rapport - <i>Rapporto</i>	1:15	1:10	1:20	1:28	1:40	
Gear red. - <i>Getriebe</i> Réduct. - <i>Riduttore</i>	B5/B5 PAM 71 Ø Flange = 160 mm Ø M* = 14 mm Ø U* = 24 mm					
Variator - <i>Regelgetr.</i> Variateur - <i>Variatore</i>	B5/B5 PAM 71/71 n° 190-1000 rpm Ø Flange 160/160 mm Ø M* =14 mm Ø U* =14 mm					
Different. - <i>Different.</i> Différent. - <i>Differenz.</i>	B5/B5 PAM 71/71 n° 0-1000 rpm Ø Flange 160/160 mm Ø M* =14 mm Ø U* =14 mm					
Motors - <i>E-Motoren</i> Moteurs - <i>Motori</i>	0.25 kW 4P 50 Hz 71A B5 (std) (0.37 kW 4P 50 Hz 71B)					
BLENDING TOOL - HOMOGENISIERWERKZEUG - OUTIL DE HOMOGENEISATION - OMOGENEIZZATORE						
RPM	35					
Ratio - <i>Untersetzung</i> Rapport - <i>Rapporto</i>	1:40					
Gear red. - <i>Getriebe</i> Réduct. - <i>Riduttore</i>	B5bi PAM 80 Ø Flange = 200 mm Ø M* = 19 mm Ø U* = 25 mm					
Motors - <i>E-Motoren</i> Moteurs - <i>Motori</i>	0.55 kW 4P 50 Hz 80A B5 (std) (0.75 kW 4P 50 Hz 80B)					

* ØM = Ø Electric motor shaft - *Welle elektromotor* - Arbre moteur électrique - *Albero motore elettrico*

* ØU = Ø Screw shaft - *Werkzeugwelle* - Arbre outil - *Albero utensile*

FINISHING - FINISH - FINITION - FINITURE

End plate	Endschild	Bride d'extrémité	Frontale	St. St. 304 / EDELSTAHL 1.4301 / AISI 304
Drive support	Antriebshalter.	Plaque de fixation	Piastra d'attacco	ALUMINIUM / ALLUMINIO
Reducer	Getriebe	Reducteur	Riduttore	ALUMINIUM / ALLUMINIO
Speed variator	Regelgetriebe	Variateur	Variatore	RAL 5010
Motor	Elektromotor	Moteur	Motore	RAL 5010

STANDARD METERING SCREWS - STANDARD-DOSIERWERKZEUGE
OUTILS DE DOSAGE STANDARD - UTENSILI DOSAGGI STD

UTD. 12		TYPE 1		
	RECTANGULAR SECTION SPIRAL WITHOUT CENTRE PIPE	WENDEL MIT RECHTECKIGEM QUERSCHNITT OHNE INNENROHR	HELICE A SECTION RECTANGULAIRE SANS TUBE INTERIEUR	ELICHE A SEZIONE RETTANGOLARE PRIVE DI TUBO INTERNO
	Light sticky materials: flour, sugar, cocoa, pellets, granular products, light and slightly sticky oxides.	Geeignet für Medien mit geringem Schüttgewicht und mit Tendenz zum Anbacken: Mehl, Zucker, Kakao, Pellets, Granulate, Oxyde mit geringem Schüttgewicht und gewisser Tendenz zum Anbacken.	Matériaux légers avec une tendance au tassement: farines, sucre, cacao, pellets, produits granulaires, oxides légers.	Materiali leggeri con tendenza all'impaccamento: farine, zucchero, cacao, pellets, prodotti granulari, ossidi leggeri moderatamente impaccati.

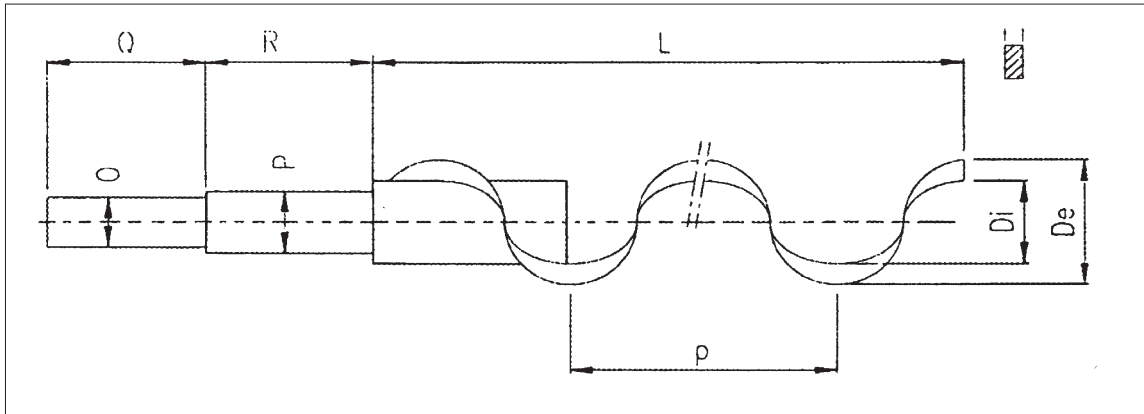

TYPE1 Rectangular section spiral without centre pipe
TYPE1 *Wendel mit rechteckigem Querschnitt ohne Innenrohr*
TYPE1 Hélice à section rectangulaire sans tube intérieur
TIPO 1 *Eliche a sezione rettangolare senza tubo interno*

MBF	Code	De	Di	p	S	L	Ø O	Ø P	Q	R	kg
042	UTD 212	26	16	30	5	403	14	25	58	81	0.5
073	UTD 312	60	40	60	5	607	24	29	96	119	3
114	UTD 412	100	67	100	5	607	24	29	96	119	5

STD BLENDING TOOLS - STD - HOMOGENISIERWERKZEUGE
HOMOGENISATEURS STD - UTENSILI OMOGENEIZZAZIONE STD

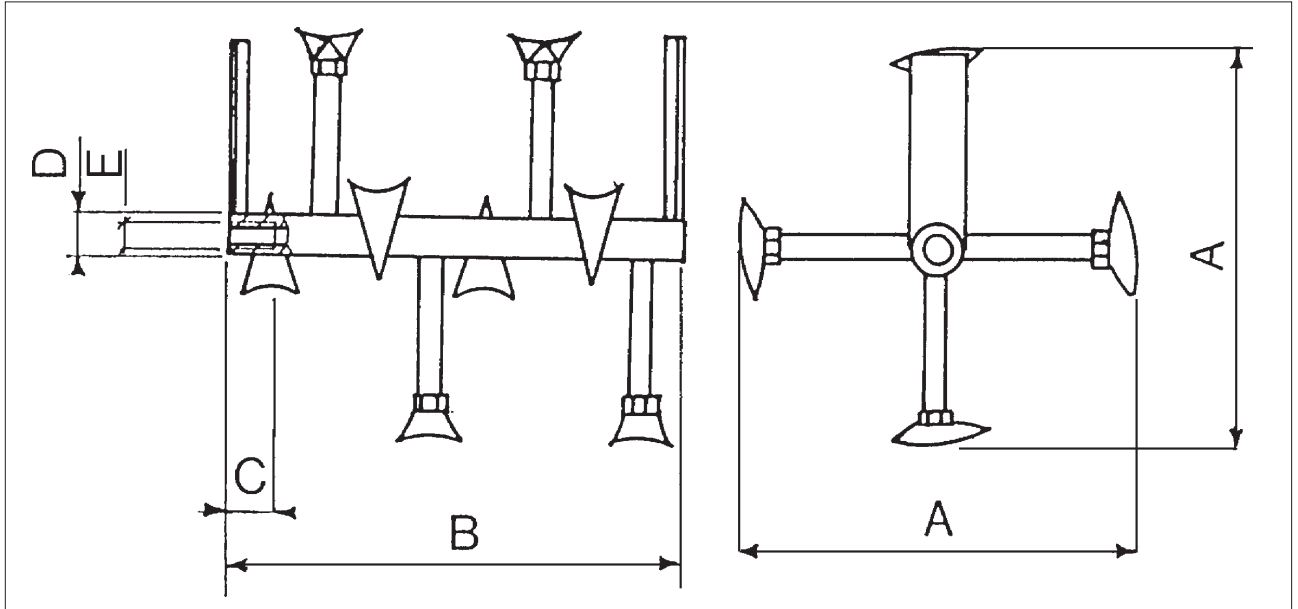
TYPE 2

MBF	Code	A	B	C	D	E	kg
042	UTO 22	130	199	25	25	M 12	1
073	UTO 23	269	349	35	35	M 16	3.5
114	UTO 24	269	349	35	35	M 16	3.5

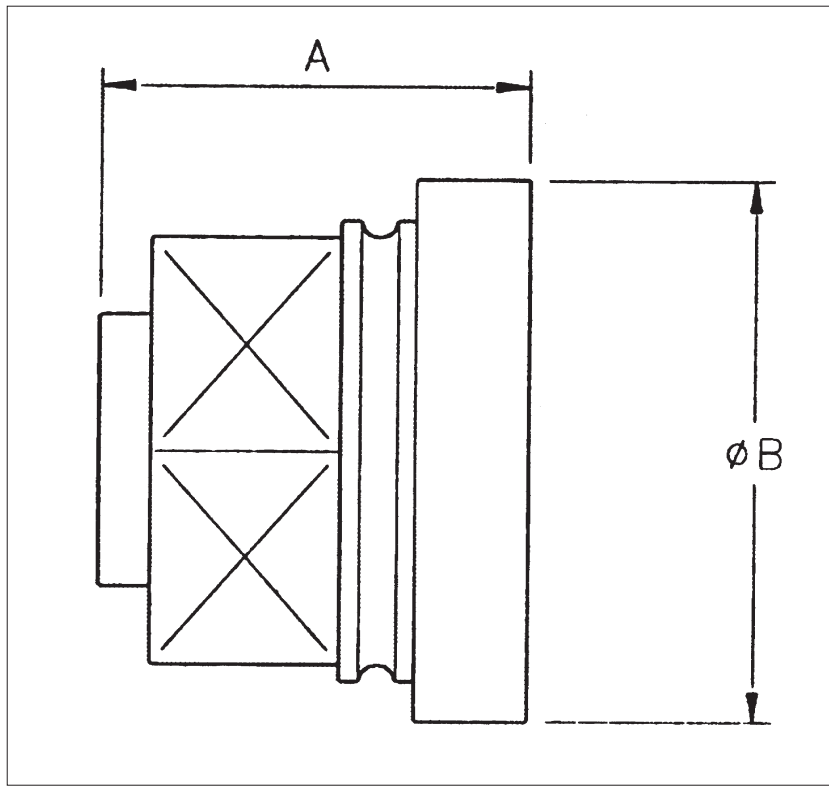



STANDARDS SEALS - STANDARD-WELLENABDICHTUNGEN - ETANCHEITEES STANDARD - TENUTE STANDARD

SINT[®]ER

MBF	Code	A	B
042	MBT N2	54	60
073	MBT N3	57	80
114	MBT N4	57	80

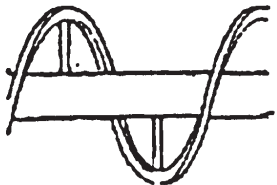
SINT[®]AL

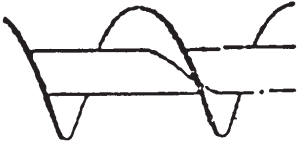
MBF	Code	A	B
042	MBT F2	54	60
073	MBT F3	57	80
114	MBT F4	57	80

SPECIAL METERING SCREWS - SPEZIALDOSIERWERKZEUGE - OUTILS DOSAGE SPECIAUX - UTENSILI DOSAGGIO SPECIALI

	UTD. 22		TYPE 2	
	RIBBON SPIRAL ON PIPE Heavy sticky materials, heavy oxides, clay	BRANDWENDEL MIT INNENROHR Geeignet für Medien mit höherem Schüttgewicht und mit Tendenz zum Anbacken: Oxyde mit höherem Schüttgewicht, Ton	HELICE A RUBAN AVEC TUBE INTERIEUR Matériaux lourds avec tendance au tassement, oxides lourdes, argiles	ELICHE A NASTRO CON TUBO INTERNO Materiali pesanti con tendenza all'impaccamento ossidi pesanti, argille
	UTD. 32		TYPE 3	
	ROUND SECTION SPIRAL WITHOUT CENTRE PIPE Light materials, granular products, pellets, PVC, polymers in pellets.	WENDEL MIT RUNDDEM QUERSCHNITT OHNE INNENROHR Geeignet für Medien mit geringem Schüttgewicht, ohne Tendenz zum Anbacken: Granulate, Pellets; PVC, Polymere in Pellets.	HELICE A SECTION RONDE SANS TUBE INTERIEUR Matériaux légers, produits granulaires, pellets, PVC, polymers en pellets.	ELICHE A SEZIONE TONDA PRIVE DI TUBO INTERNO Materiali leggeri non impaccati, prodotti granulari, pellets, PVC, polimeri in pellets.
	UTD.42		TYPE 4	
	STANDARD SCREW Heavy fluid materials metallic granules.	VOLLBLATTWENDEL MIT INNENROHR Geeignet für gut fließende Medien mit höherem Schüttgewicht: Schiefer gemahlen, Metallgranulate.	HELICE AVEC TUBE INTERIEUR Matériaux lourds et fluides, grains de métal.	ELICHE CONTINUE CON TUBO INTERNO Materiali pesanti e scorrevoli, graniglia di metalli.
	UTD. 5.		TYPE 5	
	HELICOID SCREW ON TAPERED PIPE MADE FROM SINT®ER OR SINT®AL Whenever even metering on the entire surface along with mixing of materials with different particle size, bulk density and/or fluency is required.	WENDEL MIT KONISCHER WELLE AUS SINT®ER ODER SINT®AL Findet überall Verwendung, wo eine homogene Dosierung auf der gesamten Fläche in Verbindung mit einer Durchmischung von Medien mit unterschiedlicher Körnung, Fließfähigkeit und/oder Schüttdichte erforderlich ist.	HELICE AVEC TUBE CONIQUE EN SINT®ER OU SINT®AL Où qu'une extraction homogène sur toute la surface avec des mélanges de produits à granulométries différentes, à poids spécifiques différents et/ou degrés différents de fluidité.	ELICA CON TUBO CONICO IN SINT®ER O SINT®AL Dovunque sia necessaria una estrazione omogenea su tutta la superficie con miscela di prodotti a diversa granulometria, diverso peso specifico, diverso grado di scorrevolezza.

SPECIAL METERING SCREWS - SPEZIAL-DOSIERWERKZEUGE - OUTILS DOSAGE SPECIAUX - UTENSILI DOSAGGIO SPECIALI

	UTD. 7. TYPE 7			
	SAME AS TYPE 5 BUT WITH DIFFERENT PITCH	WIE TYP 5, JEDOCH MIT UNTERSCHIEDLICHER STEIGUNG	SIMILAIRE AU TYPE 5, MAIS AVEC PAS DIFFERENT	SIMILE AL TIPO 5, MA CON PASSO DIVERSO

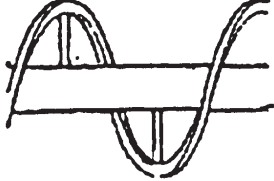
	UTD. B2 TYPE B			
	SAME AS TYPE 2 BUT EXTENDED	WIE TYP 2, JEDOCH VERLÄNGERT	SIMILAIRE AU TYPE 2, MAIS PROLONGÉ	SIMILE AL TIPO 2, MA PROLUNGATO

	UTD. D2 TYPE D			
	SAME AS TYPE 4 BUT EXTENDED	WIE TYP 4, JEDOCH VERLÄNGERT	SIMILAIRE AU TYPE 4, MAIS PROLONGÉ	SIMILE AL TIPO 4, MA PROLUNGATO

	UTD. E. TYPE E			
	SAME AS TYPE 5 BUT EXTENDED	WIE TYP 5, JEDOCH VERLÄNGERT	SIMILAIRE AU TYPE 5, MAIS PROLONGÉ	SIMILE AL TIPO 5, MA PROLUNGATO

	UTD. G. TYPE G			
	SAME AS TYPE 7 BUT EXTENDED	WIE TYP 7, JEDOCH VERLÄNGERT	SIMILAIRE AU TYPE 7, MAIS PROLONGÉ	SIMILE AL TIPO 7, MA PROLUNGATO

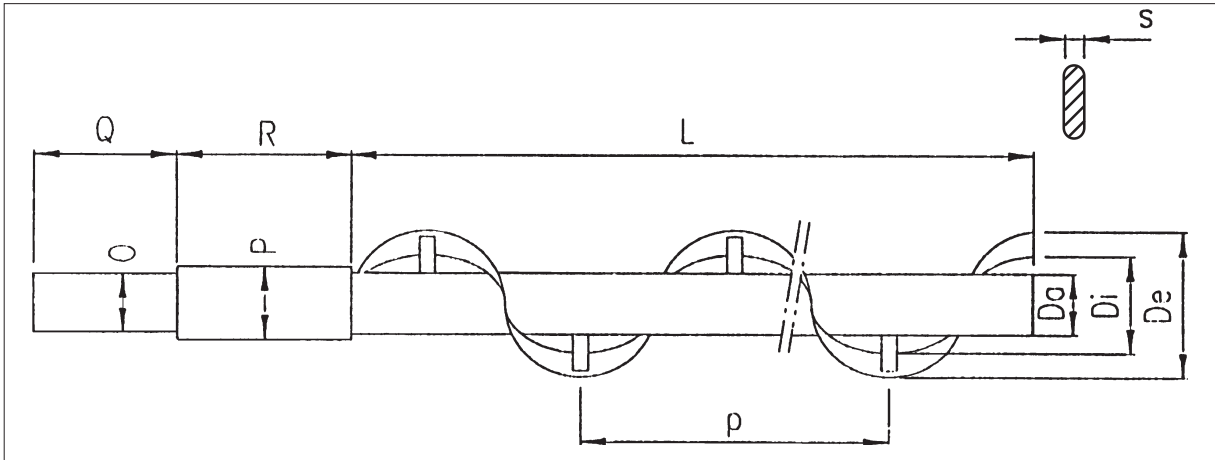
SPECIAL METERING SCREWS - SPEZIAL-DOSIERWERKZEUGE - OUTILS DOSAGE SPECIAUX - UTENSILI DOSAGGIO SPECIALI

TYPE 2 and TYPE B Ribbon flight on pipe
TYPE 2 und TYPE B Bandwendel mit Innenrohr
TYPE 2 et TYPE B à ruban avec tube intérieur
TIPO 2 e TIPO B a nastro con tubo interno

Type	MBF	Code	De	Di	Da	p	S	L	Ø O	Ø P	Q	R	kg
2	073	UTD 322	60	40	25	60	5	607	24	29	96	119	3
	114	UTD 422	100	67	25	100	5	607	24	29	96	119	4
B	073	UTD 3B2	60	40	25	60	5	857	24	29	96	119	4
	114	UTD 4B2	100	67	25	100	5	857	24	29	96	119	4.5

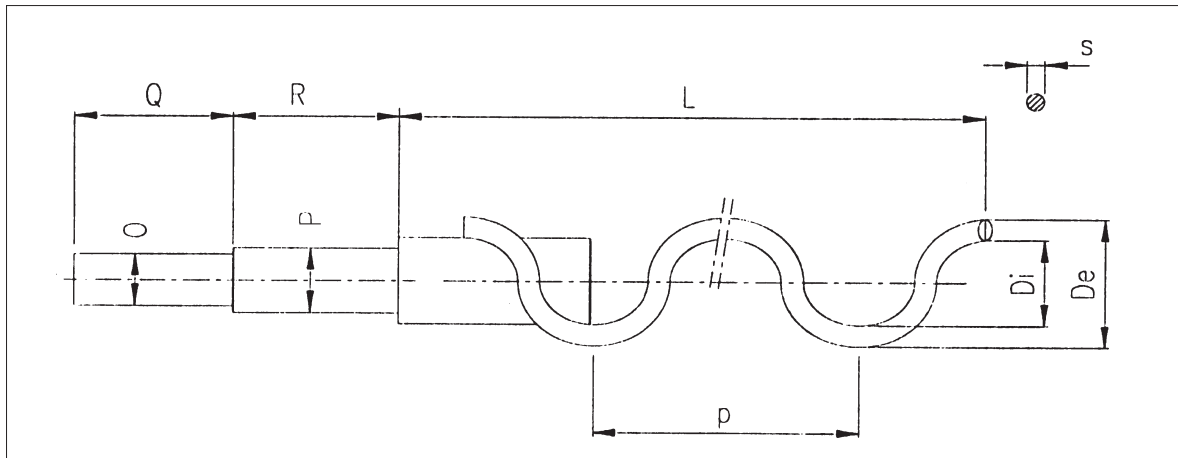

TYPE 3 Round section spiral without centre pipe
TYPE 3 Wendel mit rundem Querschnitt ohne Innenrohr
TYPE 3 Hélice à section rectangulaire sans tube intérieur
TIPO 3 Eliche sezione tonda senza tubo interno

Type	MBF	Code	De	Di	p	S	L	Ø O	Ø P	Q	R	kg
3	042	UTD 232	26	16	30	5	403	14	25	58	81	0.5
	073	UTD 332	57	40	60	8	607	24	29	96	119	3
	114	UTD 432	90	70	75	10	607	24	29	96	119	5

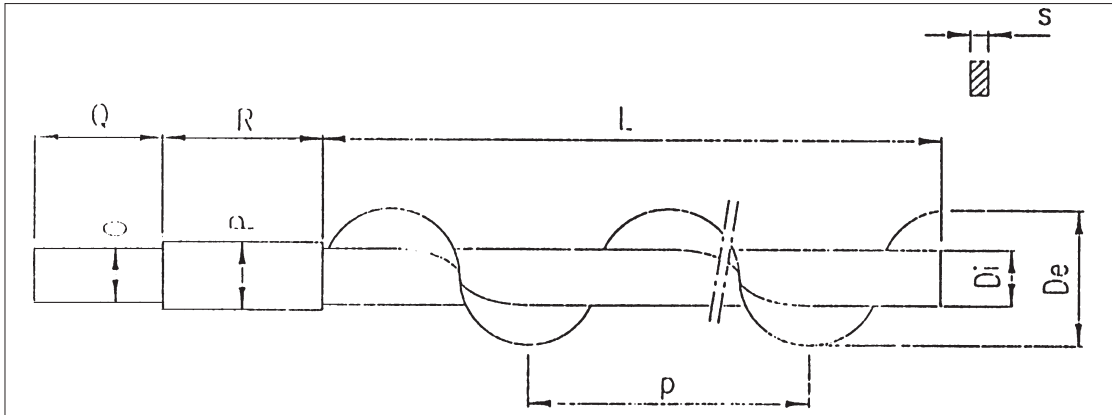
SPECIAL METERING SCREWS - SPEZIAL-DOSIERWERKZEUGE - OUTILS DOSAGE SPECIAUX - UTENSILI DOSAGGIO SPECIALI

TYPE 4 and **TYPE D** standard screws
TYPE 4 und **TYPE D** Vollblattwendeln mit Innenrohr
TYPE 4 et **TYPE D** hélices continues avec tube interieur
TIPO 4 e **TIPO D** eliche continue con tubo interno

EXTENDED
 VERLÄNGERT
 RALLONGE
 ALLUNGATO

Type	MBF	Code	De	Di	p	S	L	Ø O	Ø P	Q	R	kg
4	042	UTD 242	30	20	30	5	403	14	25	58	81	1.5
	073	UTD 342	57	25	60	5	607	24	29	96	119	3.5
	114	UTD 442	90	32	100	5	607	24	29	96	119	6
D	042	UTD 2D2	30	20	30	5	573	14	25	58	81	2
	073	UTD 3D2	57	25	60	5	857	24	29	96	118	5
	114	UTD 4D2	90	32	100	5	857	24	29	96	119	7.5

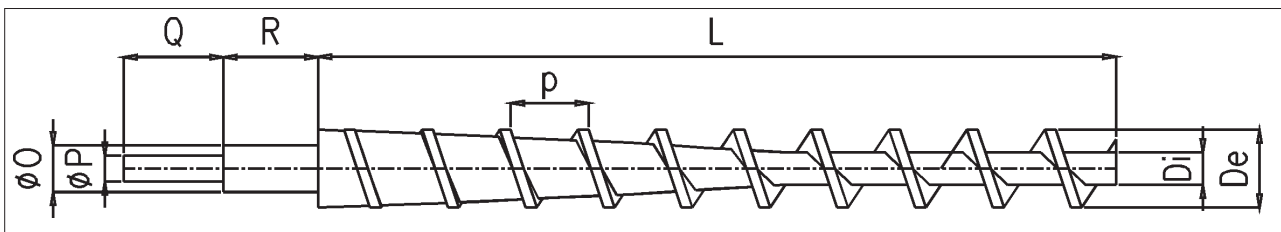

TYPE 5 and **TYPE E** screws made of SINT[®]ER or SINT[®]AL with tapered pipe
TYPE 5 und **TYPE E** Wendeln aus SINT[®]ER oder SINT[®]AL mit konischem Innenrohr
TYPE 5 et **TYPE E** Hélices en SINT[®]ER ou SINT[®]AL avec tube conique
TIPO 5 e **TIPO E** Eliche in SINT[®]ER o SINT[®]AL con tubo conico

EXTENDED
 VERLÄNGERT
 RALLONGE
 ALLUNGATO

Type	MBF	Code	De	Di	p	L	Ø O	Ø P	Q	R	kg
5	042	UTD 25.	30	15	20	403	25	14	58	81	0.6
	073	UTD 35.	60	25	60	607	30	24	96	119	2
	114	UTD 45.	100	35	100	607	30	24	96	119	3
E	042	UTD 2E.	30	15	20	573	25	14	58	81	0.85
	073	UTD 3E.	60	25	60	857	30	24	96	119	2
	114	UTD 4E.	100	35	100	857	30	24	96	119	3.5

4 SINT[®]ER
 5 SINT[®]AL

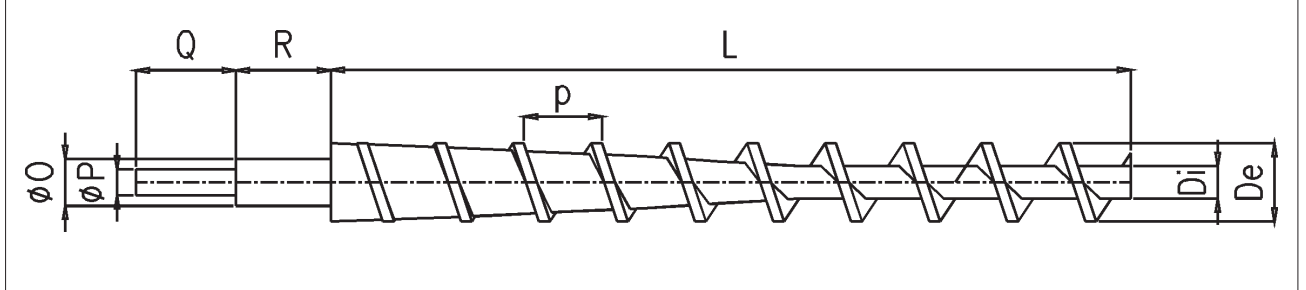
SPECIAL METERING SCREWS - SPEZIAL-DOSIERWERKZEUGE - OUTILS DOSAGE SPECIAUX - UTENSILI DOSAGGIO SPECIALI

TYPE 7- G Screw with tapered centre pipe made of SINT[®]ER or SINT[®]AL
TYPE 7- G Vollblattwendel mit konischem Innenrohr aus SINT[®]ER oder SINT[®]AL
TYPE 7- G Hélice continue avec tube intérieur conique en SINT[®]ER ou SINT[®]AL
TIPO 7- G Elica continua con tubo interno conico in SINT[®]ER o SINT[®]AL

Type	MBF	Code	De	Di	p	L	Ø O	Ø P	Q	R	kg
7	042	UTD 27 .	30	20	30	403	25	14	58	81	0.6
G	042	UTD 2G .	30	20	30	573	25	14	58	81	0.7

4	SINT [®] ER
5	SINT [®] AL

SPECIAL SHAFT SEAL - SONDER-WELLENABDICHTUNG - ETANCHEITE SPECIALE - TENUTA SPECIALE

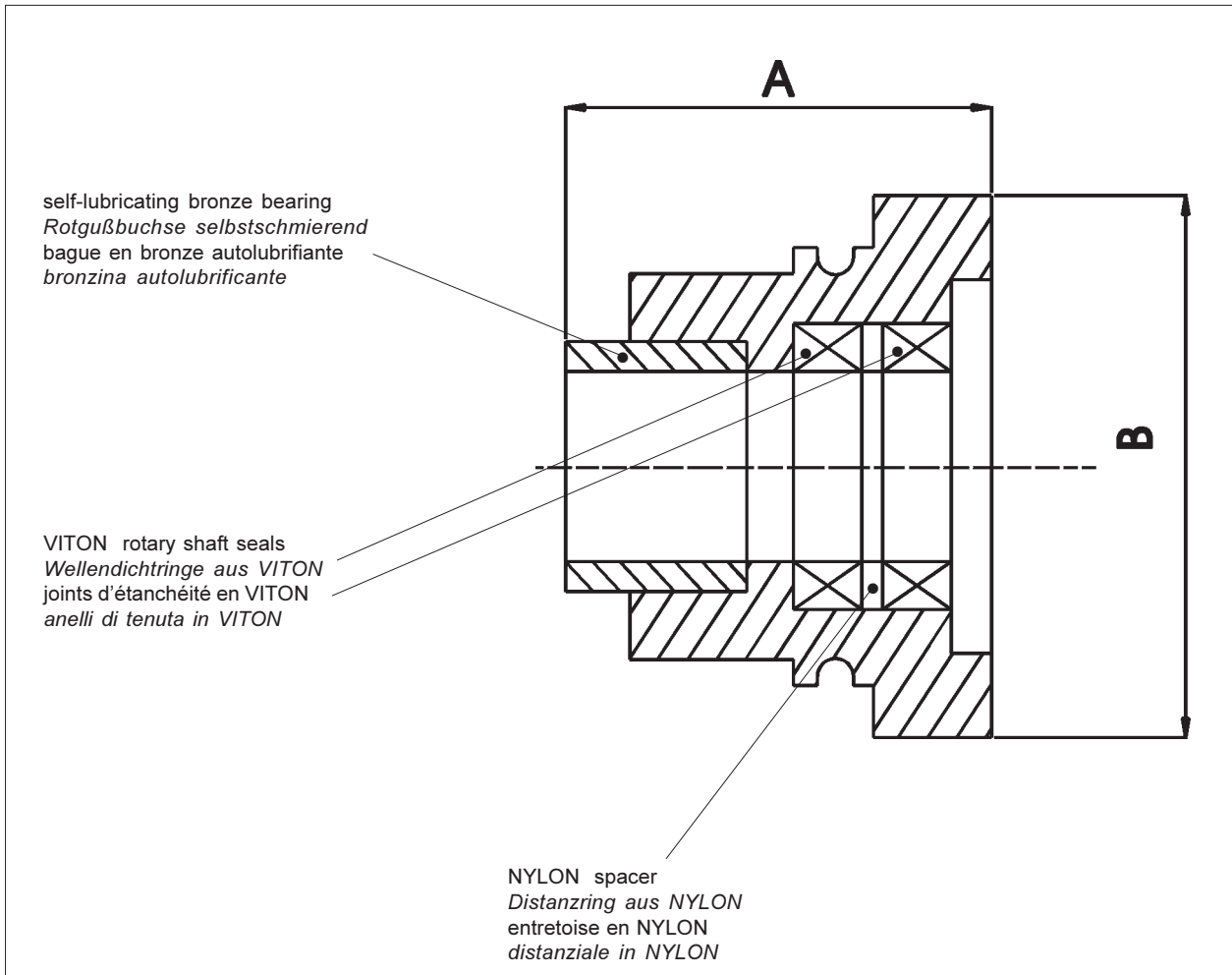

MBF	Code	A	B	kg
042	MBTX2	54	60	0.35
073	MBTX3	57	80	0.5
114	MBTX4	57	80	0.5

**SPECIAL SHAFT SEAL WITH GREASING - SONDER-WELLENABDICHTUNG MIT FETT
 ETANCHEITE SPECIALE AVEC GRAISSE - TENUTA SPECIALE CON INGRASSAGGIO**

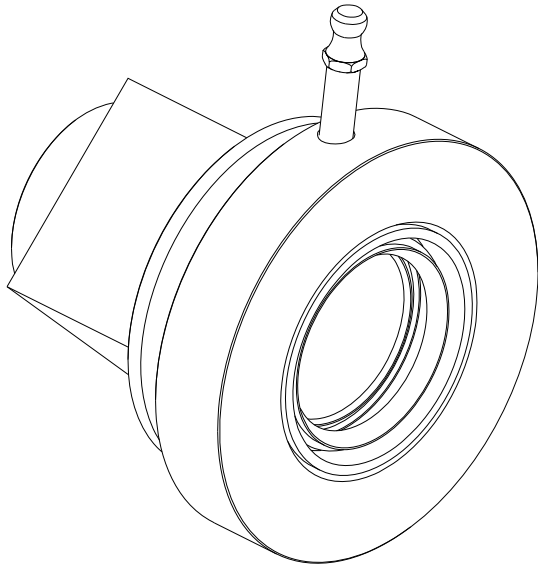
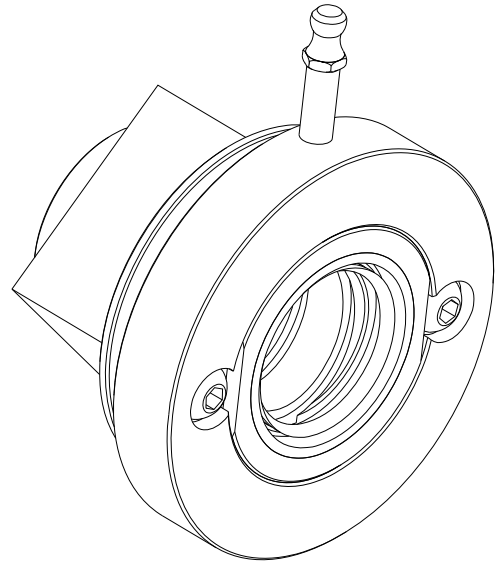
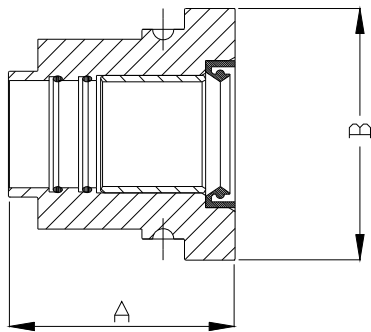
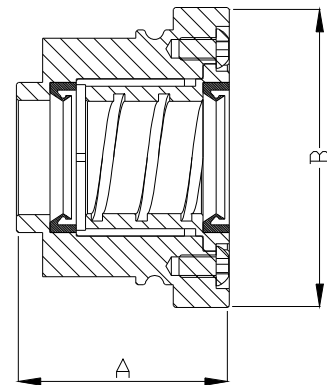
MBTT 2

MBTT 3 - 4

MBF	Code	A	B	kg
042	MBTT2	54	60	0.35
073	MBTT3	57	80	0.5
114	MBTT4	57	80	0.5

N.B. : The MBTT seal is standard with stainless steel version only

N.B. : MBTT-Wellenabdichtung ist nur für Edelstahlversion Standard

N.B. : L'étanchéité MBTT est standard seulement pour la version en acier inox

N.B. : La tenuta MBTT è STD solo sulla versione in AISI

MBF	073	N	UD1	SST	UO2	TN	A	1	0025	0037
-----	-----	---	-----	-----	-----	----	---	---	------	------

DRIVE POWER BLENDING TOOL

DRIVE POWER METERING SCREW

VOLTAGE / CYCLES

TYPE OF DRIVE

SHAFT SEALS

BLENDING TOOL

METERING SCREW

ELASTOMER BODY MATERIAL

DIAMETER

UD1 UD2 UD3 UD4 UD5 UD7 UDB UDD UDE

- TN SINT®ER ©
- TF SINT®AL
- TX AISI 304L
- TT AISI 304L GREASING
- UO1
- UO2

- SST STANDARD FEEDER PIPE
- SPL EXTENDED FEEDER PIPE
- SSR LINER FEEDER PIPE
- SPR EXTENDED LINER FEEDER PIPE
- SSE STD EXTRACTABLE FEEDER PIPE
- SPE EXTENDED EXTRACTABLE FEEDER PIPE

D = 042	D = 73	D = 114
0025 = 0.25 kW ©	0055 = 0.55 kW ©	0055 = 0.55 kW ©
0037 = 0.37 kW	0075 = 0.75 kW	0075 = 0.75 kW

D = 042*	D = 73	D = 114
0012 = 0.12 kW ©	0025 = 0.25 kW ©	0025 = 0.25 kW ©
0018 = 0.18 kW	0037 = 0.37 kW	0037 = 0.37 kW
* with variable speed drive 0.25 kW B5 motor is standard		

Volt / Hz	INDEX
without motor	0
230-400/50	1
400-690/50	2
260-440/50	4
260-440/60	5
230-400/60	6
400-690/60	8
230-460/60	P

CODE	INDEX	GEAR RATIO	RPM	NOTES
Fixed speed				
V.C.A.	A	1/10	140	© *
V.C.B.	B	1/15	93	
V.C.C.	C	1/20	70	
V.C.D.	D	1/28	50	
V.C.E.	E	1/40	35	
Fixed speed NEMA standards				
V.C.N.F.	F	1/10	140	© §
V.C.N.G.	G	1/15	93	
V.C.N.H.	H	1/28	50	
V.C.N.L.	L	1/40	35	
Variable speed				
V.V.M.	M	1/10	19-100	© *
V.V.N.	N	1/15	13-67	
V.V.P.	P	1/20	10-50	
V.V.Q.	Q	1/28	7-36	
V.V.R.	R	1/40	5-25	
Variable speed NEMA standards				
V.V.N.S.	S	1/10	19 -100	© §
V.V.N.T.	T	1/15	13-67	
V.V.N.U.	U	1/28	7-36	
V.V.N.V.	V	1/40	5-25	
Variable speed with differential				
V.D.	Z	1/10	5-90	© *
V.D.	W	1/15	4-60	
V.D.	Y	1/20	3-45	
V.D.	J	1/28	2-36	
V.D.	X	1/40	1-22	
Variable speed with differential norme NEMA				
V.D.	1	1/10	19-100	© §
V.D.	2	1/15	13-67	
V.D.	3	1/28	7-36	
V.D.	4	1/40	5-25	

* only MBF 073 - 114
 § only MBF 042

- N = STANDARD ©
- F = FOOD GRADE
- A = AISI 304L

042 - 073 - 114

© = STANDARD



MBF
 - ORDER CODES
 - BESTELLCODE
 - CODES DE COMMANDE
 - CODICI DI ORDINAZIONE

DEUTSCH

07.02 / 03.00

1

WA.02515 T. 25

MBF	073	N	UD1	SST	UO2	TN	A	1	0025	0037
-----	-----	---	-----	-----	-----	----	---	---	------	------

ANTRIEBSLEISTUNG
HOMOGENISIER-
WERKZEUG

ANTRIEBSLEISTUNG
DOSIERWERKZEUGE

SPANNUNG / FREQUENZ

ANTRIEBSTYP

WELLENAB-
DICHTUNGEN

HOMOGENISIERWERKZEUGE

DOSIERWERKZEUGE

WERKSTOFF ELASTOMERGEHÄUSE

DURCHMESSER

MIKRODOSIERER TYP "MBF"

D = 042	D = 73	D = 114
0025 = 0.25 kW ©	0055 = 0.55 kW ©	0055 = 0.55 kW ©
0037 = 0.37 kW	0075 = 0.75 kW	0075 = 0.75 kW

D = 042*	D = 73	D = 114
0012 = 0.12 kW ©	0025 = 0.25 kW ©	0025 = 0.25 kW ©
0018 = 0.18 kW	0037 = 0.37 kW	0037 = 0.37 kW

*bei Regelantrieb ist 0.25 kW - Motor in Bauform B5 Standard

Volt / Hz	INDEX
ohne Motor	0
230-400/50	1
400-690/50	2
260-440/50	4
260-440/60	5
230-400/60	6
400-690/60	8
230-460/60	P

CODE	INDEX	GETRIEBE- UNTERSETZUNG	U / min	NOTA
Feste Drehzahl				
V.C.A.	A	1:10	140	© *
V.C.B.	B	1:15	93	
V.C.C.	C	1:20	70	
V.C.D.	D	1:28	50	
V.C.E.	E	1:40	35	
Feste Drehzahl NEMA-Norm				
V.C.N.F.	F	1:10	140	© §
V.C.N.G.	H	1:28	50	
V.C.N.L.	L	1:40	35	
Regelbare Drehzahl				
V.V.M.	M	1:10	19-100	© *
V.V.N.	N	1:15	13-67	
V.V.P.	P	1:20	10-50	
V.V.Q.	Q	1:28	7-36	
V.V.R.	R	1:40	5-25	
Regelbare Drehz. NEMA-Norm				
V.V.N.S.	S	1:10	19-100	© §
V.V.N.T.	T	1:15	13-67	
V.V.N.U.	U	1:28	7-36	
V.V.N.V.	V	1:40	5-25	
Regelb. Drehz. mit Differential				
V.D.	Z	1:10	5-90	© *
V.D.	W	1:15	4-60	
V.D.	Y	1:20	3-45	
V.D.	J	1:28	2-36	
V.D.	X	1:40	1-22	
Regelb. Drehz. mit Differential NEMA-Norm				
V.D.	1	1:10	19-100	© §
V.D.	2	1:15	13-67	
V.D.	3	1:28	7-36	
V.D.	4	1:40	5-25	

* nur für MBF 073 - 114

§ nur für MBF 042

- N = STANDARD ©
- F = NAHRUNGSMITTELTAUGLICH
- A = EDELSTAHL 1.4301

042 - 073 - 114

© = STANDARD

UD1 UD2 UD3 UD4 UD5 UD7 UDB UDDUDE

MBF	073	N	UD1	SST	UO2	TN	A	1	0025	0037
-----	-----	---	-----	-----	-----	----	---	---	------	------

PUISSANCE MOT. OUTIL DE HOMOGENEISATION

D = 042	D = 73	D = 114
0025 = 0.25 kW ©	0055 = 0.55 kW ©	0055 = 0.55 kW ©
0037 = 0.37 kW	0075 = 0.75 kW	0075 = 0.75 kW

PUISSANCE MOT. OUTIL DE DOSAGE

D = 042*	D = 73	D = 114
0012 = 0.12 kW ©	0025 = 0.25 kW ©	0025 = 0.25 kW ©
0018 = 0.18 kW	0037 = 0.37 kW	0037 = 0.37 kW
*avec vitesse réglable moteur 0.25 kW en B5 est standard		

VOLTAGE / FREQUENCE D'ALIMENTATION

Voit / Hz	INDEX
sans moteur	0
230-400/50	1
400-690/50	2
260-440/50	4
260-440/60	5
230-400/60	6
400-690/60	8
230-460/60	P

TYPE MOTORISATION

CODE	INDEX	RAPPORT DE REDUCTION	TPM	NOTES
Vitesse constante				
V.C.A.	A	1:10	140	© *
V.C.B.	B	1:15	93	
V.C.C.	C	1:20	70	
V.C.D.	D	1:28	50	
V.C.E.	E	1:40	35	
Vitesse constante normes NEMA				
V.C.N.F.	F	1:10	140	© §
V.C.N.G.	G	1:15	93	
V.C.N.H.	H	1:28	50	
V.C.N.L.	L	1:40	35	
Vitesse variable				
V.V.M.	M	1:10	19-100	© *
V.V.N.	N	1:15	13-67	
V.V.P.	P	1:20	10-50	
V.V.Q.	Q	1:28	7-36	
V.V.R.	R	1:40	5-25	
Vitesse variable normes NEMA				
V.V.N.S.	S	1:10	19-100	© §
V.V.N.T.	T	1:15	13-67	
V.V.N.U.	U	1:28	7-36	
V.V.N.V.	V	1:40	5-25	
Vitesse variable avec différentiel				
V.D.	Z	1:10	5-90	© *
V.D.	W	1:15	4-60	
V.D.	Y	1:20	3-45	
V.D.	J	1:28	2-36	
V.D.	X	1:40	1-22	
Vitesse variable avec différentiel normes NEMA				
V.D.	1	1:10	19-100	© §
V.D.	2	1:15	13-67	
V.D.	3	1:28	7-36	
V.D.	4	1:40	5-25	

- **TN** SINT®ER ©
 - **TF** SINT®AL
 - **TX** AISI 304L
 - **TT** AISI 304L AVEC GRAISSE
- ETANCHEITES
- **UO1**
 - **UO2**
- OUTIL DE HOMOGENEIS.

- **SST** TUBE DE DOSAGE
 - **SPL** TUBE DE DOSAGE RALLONGEE
 - **SSR** TUBE DE DOSAGE AVEC REVETEMENT INT.
 - **SPR** TUBE DE DOSAGE RALLONGEE AVEC REVETEMENT INTERIEUR
 - **SSE** STD TUBE DE DOSAGE EXTRACTIBLE
 - **SPE** TUBE DE DOSAGE RALLONGEE ET EXTRACTIBLE
- OUTIL DE DOSAGE

UD1 UD2 UD3 UD4 UD5 UD7 UDB UDD UDE

MATERIAU CORPS ELASTOMERE

DIAMETRE

* seulement pour MBF 073 - 114
 § seulement pour MBF 042

- **N** = STANDARD ©
- **F** = UTILISATION ALIMENTAIRE
- **A** = AISI 304L

042 - 073 - 114

MICRODOSEUR TYPE "MBF"

© = STANDARD



MBF
 - ORDER CODES
 - BESTELLCODE
 - CODES DE COMMANDE
 - CODICI DI ORDINAZIONE

MBF	073	N	UD1	SST	UO2	TN	A	1	0025	0037
-----	-----	---	-----	-----	-----	----	---	---	------	------

POTENZA MOT. UTENSILE DI OMOGENEIZZAZIONE

POTENZA MOT. UTENS. DOSAGGIO

TENSIONE / FREQUENZA D'ALIMENTAZIONE

TIPO MOTORIZZAZIONE

TENUTE

UTENSILE DI OMOGENEIZZAZIONE

UTENSILE DOSAGGIO

MATERIALE CORPO ELASTOMERO

DIAMETRO

D = 042	D = 73	D = 114
0025 = 0.25 kW ©	0055 = 0.55 kW ©	0055 = 0.55 kW ©
0037 = 0.37 kW	0075 = 0.75 kW	0075 = 0.75 kW

D = 042*	D = 73	D = 114
0012 = 0.12 kW ©	0025 = 0.25 kW ©	0025 = 0.25 kW ©
0018 = 0.18 kW	0037 = 0.37 kW	0037 = 0.37 kW
* con velocità variabile STD motore 0.25 kW B5		

VOLT / Hz	INDICE
senza motore	0
230-400/50	1
400-690/50	2
260-440/50	4
260-440/60	5
230-400/60	6
400-690/60	8
230-460/60	P

- TN SINT®ER©
- TF SINT®AL
- TX AISI 304L
- TT AISI 304L Ingrassato
- UO1
- UO2

- SST SCARICO STD
- SPL SCARICO PROLUNGATO
- SSR SCARICO INTERNAMENTE RIVESTITO
- SPR SCARICO PROLUNGATO INTERNAMENTE RIVESTITO
- SSE SCARICO STANDARD ESTRAIBILE
- SPE SCARICO PROLUNGATO ESTRAIBILE

UD1 UD2 UD3 UD4 UD5 UD7 UDB UDDUDE

CODIFICA	INDICE	RAPPORTO DI RIDUZIONE	RPM	NOTE
Velocità costante				
V.C.A.	A	1:10	140	© *
V.C.B.	B	1:15	93	
V.C.C.	C	1:20	70	
V.C.D.	D	1:28	50	
V.C.E.	E	1:40	35	
Velocità costante norme NEMA				
V.C.N.F.	F	1:10	140	© §
V.C.N.G.	G	1:15	93	
V.C.N.H.	H	1:28	50	
V.C.N.L.	L	1:40	35	
Velocità variabile				
V.V.M.	M	1:10	19-100	© *
V.V.N.	N	1:15	13-67	
V.V.P.	P	1:20	10-50	
V.V.Q.	Q	1:28	7-36	
V.V.R.	R	1:40	5-25	
Velocità variabile norme NEMA				
V.V.N.S.	S	1:10	19-100	© §
V.V.N.T.	T	1:15	13-67	
V.V.N.U.	U	1:28	7-36	
V.V.N.V.	V	1:40	5-25	
Velocità variabile con differenziale				
V.D.	Z	1:10	5-90	© *
V.D.	W	1:15	4-60	
V.D.	Y	1:20	3-45	
V.D.	J	1:28	2-36	
V.D.	X	1:40	1-22	
Velocità variabile con differenziale norme NEMA				
V.D.	1	1:10	19-100	© §
V.D.	2	1:15	13-67	
V.D.	3	1:28	7-36	
V.D.	4	1:40	5-25	

* solo per MBF 073 - 114
 § solo per MBF 042

- N = STD ©
- F = USO ALIMENTARE
- A = IN AISI 304L

042 - 073 - 114

© = STANDARD

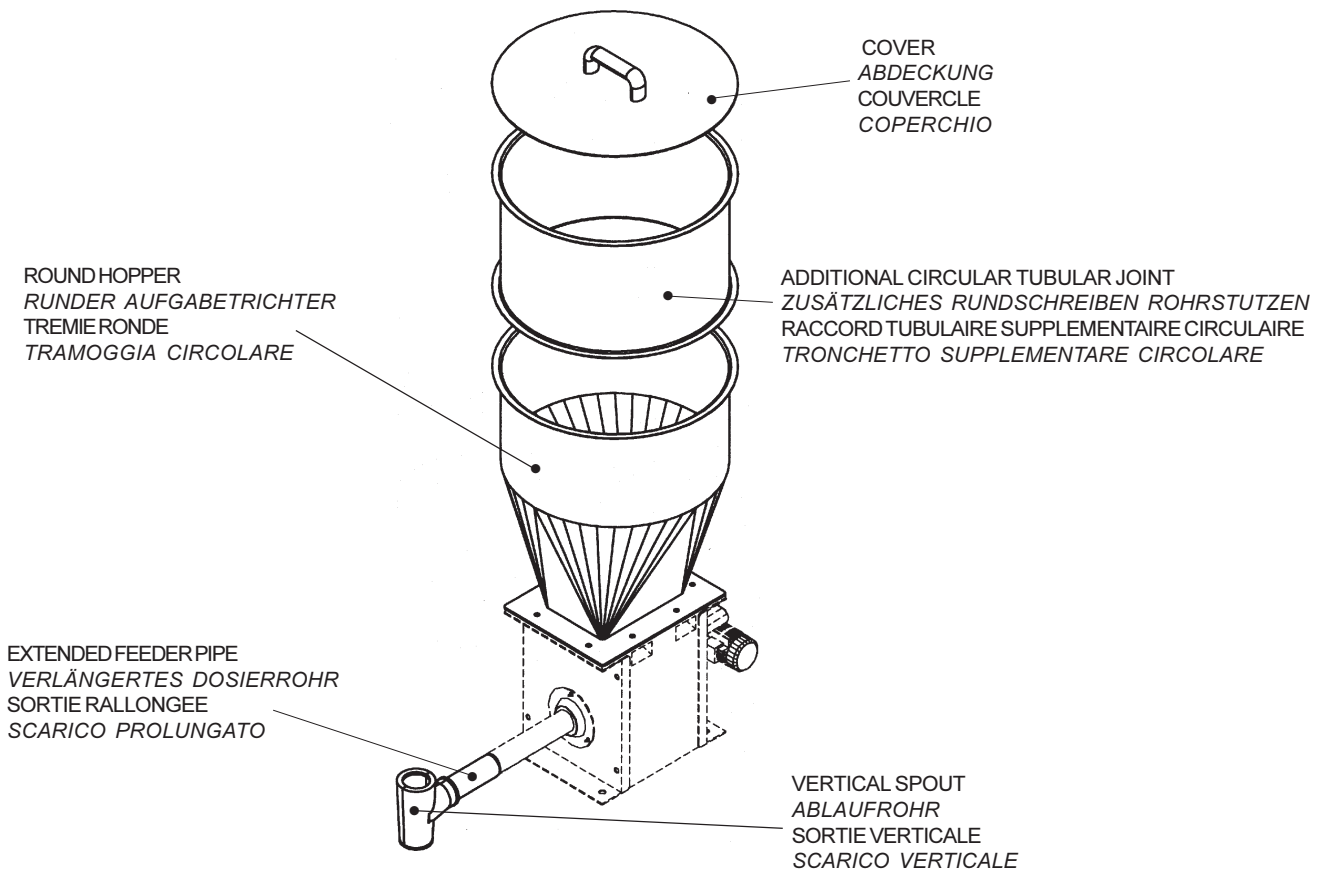
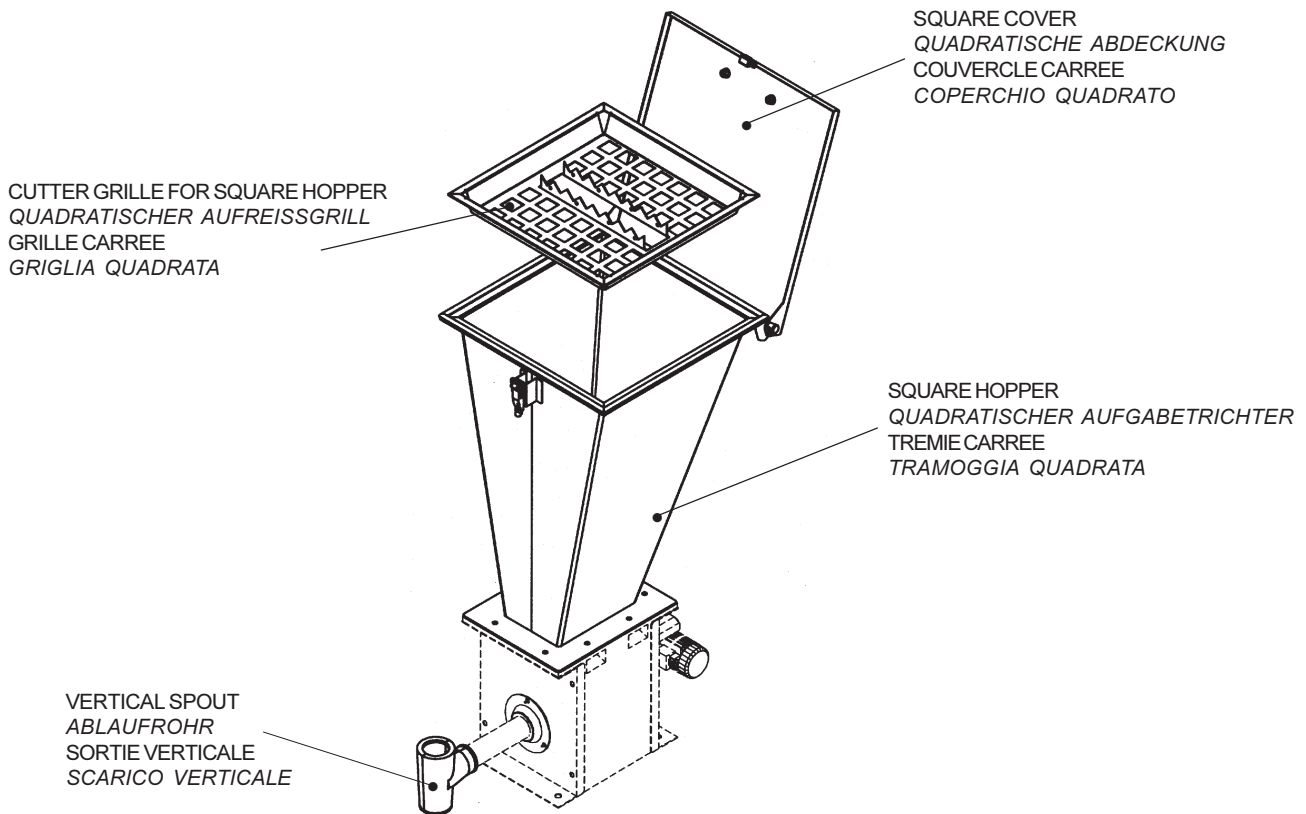

SQUARE HOPPER - QUADRATISCHER AUFGABETRICHTER - TREMIE CARREE - TRAMOGGIA QUADRATA

M D X T S 1 2

2: Stainless steel - Edelstahl 1.4301 - Inox 304 - AISI 304

Type hopper
 Trichtergröße
 Type de trémie
 Grandezza tramoggia

1	MBF 042
2	MBF 073 -114

Square hopper
 Quadratischer Aufgabetrichter
 Trémie carrée
 Tramoggia quadrata

Micro batch feeder accessories
 Zubehör Mikrodosierer
 Accessoires microdoseur
 Accessori microdosatore

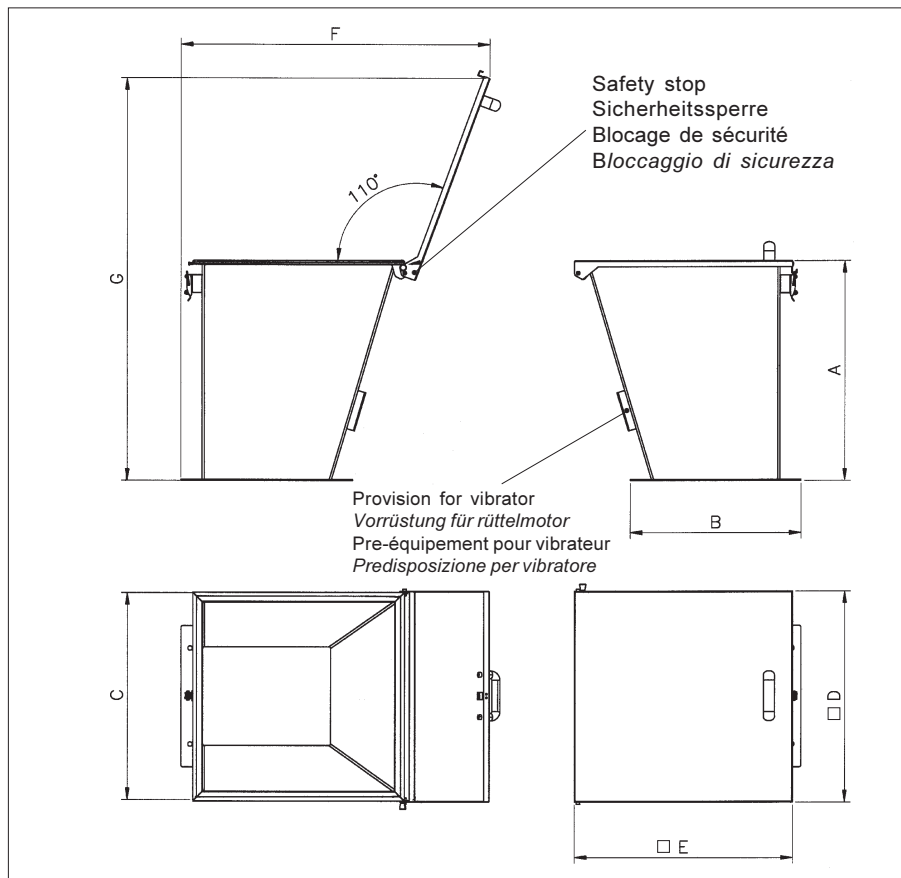

MDXTS	Suitable for - Passend zu Pour type - Idoneo MBF	A	B	C	□ D	□ E	F	G	dm ³	kg
12	042	600	310	428	434	445	640	980	25	12
22	073 - 114	600	466	575	582	595	840	1120	75	19

ROUND HOPPER - RUNDER AUFGABETRICHTER - TREMIE RONDE - TRAMOGGIA CIRCOLARE

M	D	X	T	R	1	2
---	---	---	---	---	---	---

2: Stainless steel - *Edelstahl 1.4301 - Inox 304 - AISI 304*

Type hopper
Trichtergröße
 Type de trémie
Grandezza tramoggia

1	MBF 042
2	MBF 073 -114

Round hopper
Runder Aufgabetrichter
 Trémie ronde
Tramoggia circolare

Micro batch feeder accessories
Zubehör zu Mikrodosierer
 Accessoires microdoseur
 Accessori microdosatore

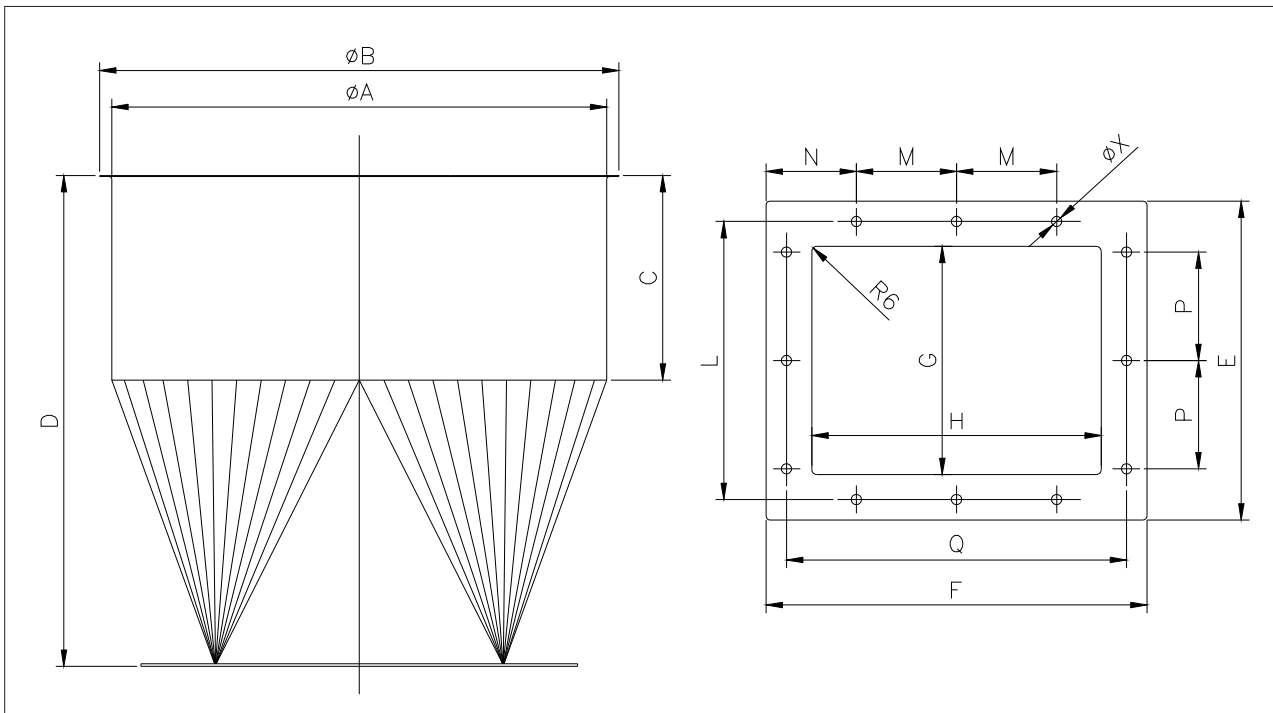

MDXTR	Suitable for - <i>Passend zu</i> Pour type - <i>Idoneo</i> MBF	ϕA	ϕB	C	D	E	F	G	H	L	M	N	P	Q	Holes - <i>Bohrungen</i> Trous - <i>Fori</i> X		dm ³	kg
															ϕ	n°		
12	042	408	436	200	500	250	310	140	200	200	110	100	130	260	9	8	52	12
22	073 - 114	630	636	250	600	390	466	279	354	340	122.5	110.5	132.5	416	12.5	12	120	20

ADDITIONAL CIRCULAR TUBULAR JOINT - ZUSÄTZLICHES RUNDSCHREIBEN ROHRSTUTZEN
RACCORD TUBULAIRE SUPPLEMENTAIRE CIRCULAIRE - TRONCHETTO SUPPLEMENTARE CIRCOLARE

M	D	X	A	R	1	2
---	---	---	---	---	---	---

2: Stainless steel - *Edelstahl 1.4301* - *Inox 304* - *AISI 304*

Type hopper
Trichtergröße
 Type de trémie
Grandezza tramoggia

1	MBF 042
2	MBF 073 -114

Additional circular tubular joint
Zusätzliches rundschreiben Rohrstutzen
Raccord tubulaire supplémentaire circulaire
Tronchetto supplementare circolare

Micro batch feeder accessories
Zubehör zu Mikrodosierer
Accessoires microdoseur
Accessori microdosatore

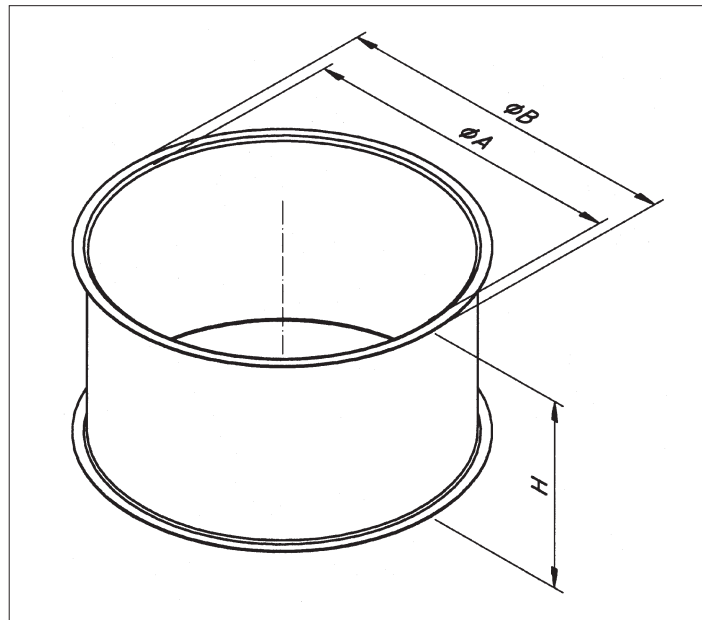

MDXAR	Suitable for - <i>Passend zu</i> <i>Pour type - Idoneo</i> MBF	Ø A	Ø B	H	dm ³
12	042	406	436	200	25
22	073-114	605	635	180	50

CUTTER GRILLE FOR SQUARE HOPPER - QUADRATISCHER AUFREISSGRILL - GRILLE CARREE - GRIGLIA QUADRATA

M D X G S 1 2

2: Stainless steel - *Edelstahl 1.4301 - Inox 304 - AISI 304*

Type hopper
Trichtergröße
 Type de trémie
Grandezza tramoggia

1	MBF 042
2	MBF 073 -114

Type hopper cutter grille
Grill
 Type de grille
Griglia quadrata tagliasacchi

Micro batch feeder accessories
Zubehör Mikrodosierer
 Accessoires microdoseur
Accessori per microdosatore

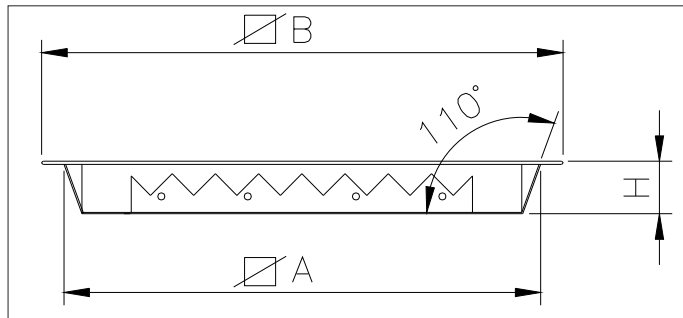

MDXGS	Suitable for - <i>Passend zu</i> Pour type - <i>Idoneo</i> MBF	□ A	□ B	H	kg
12	042	345	410	40	2
22	073 - 114	495	555	40	3

FLANGES - FLANSCHEN
 BRIDES - FLANGIATURE

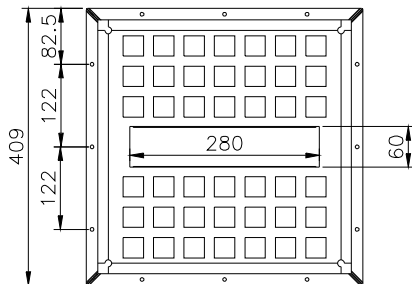

MDXGS12

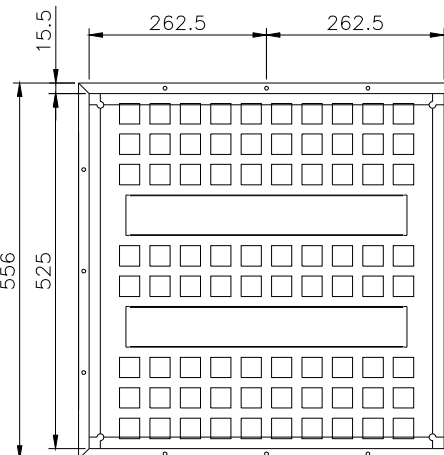

MDXGS22

ROUND COVER - RUNDE ABDECKUNG - COUVERCLE ROND - COPERCHIO TONDO

M D X C R 1 2

2: Stainless steel - *Edelstahl 1.4301* - *Inox 304* - *AISI 304*

Type hopper
Trichtergröße
 Type de trémie
Grandezza tramoggia

1	MBF 042
2	MBF 073 -114

Round cover
Runde Abdeckung
 Couvercle rond
Coperchio tondo

Micro- batch feeder accessories
Zubehör Mikrodosierer
 Accessoires microdoseur
Accessori per microdosatore

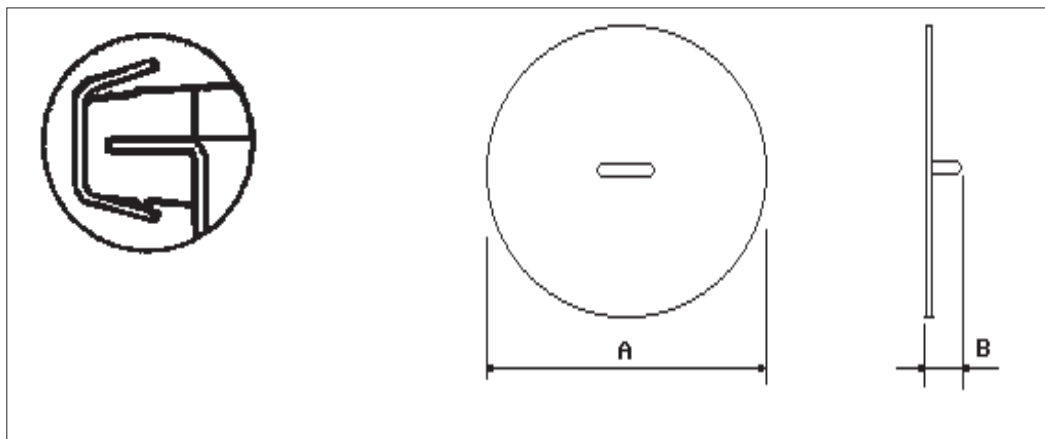

MDXCR	Suitable for - <i>Passend zu</i> Pour type - <i>Idoneo</i> MBF	A	B	kg
12	042	436	50	2
22	073 - 114	635	50	3

**PNEUMATIC BALL VIBRATORS - DRUCKLUFT-KUGELVIBRATOREN
 VIBRATEURS PNEUMATIQUES A BILLE - VIBRATORI PNEUMATICI A SFERA
 "S"**

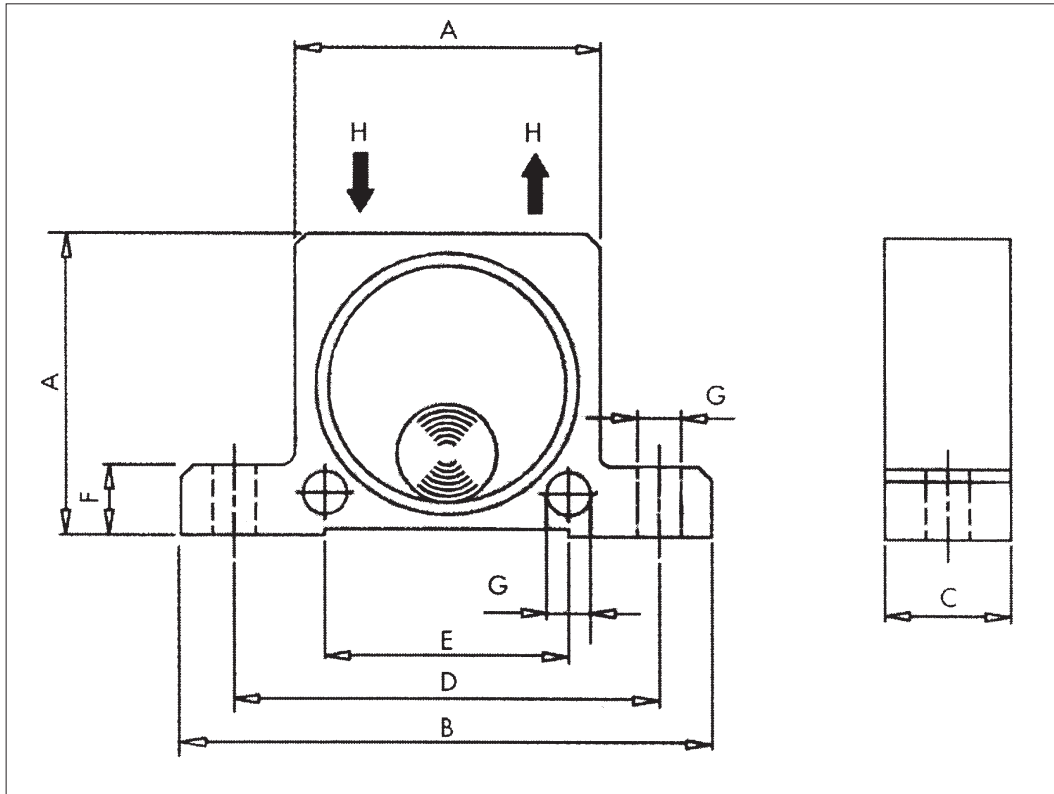

Dimensions - Abmessungen - Dimensions - Dimensioni

Type	A		B		C		D		E		F		G		H	kg	
	mm	in	mm	in	mm	in	mm	in	mm	in	mm	in	mm	in		kg	lbs
S 20	80	3.15	128	5.04	33	1.30	104	4.09	60	2.36	16	0.63	9	0.35	1/4"	0.53	1.17
S 25					38	1.50										0.63	1.39

Performance data - Leistungsdaten - Performances - Prestazioni

Type	Vibrations - Schwingungswen Vibrations - Vibrazioni min			Fc max. kg						Air consumption - Luftverbrauch Consommation d'air - Consumo d'aria l/min					
	2 bar 29 psi	4 bar 58 psi	6 bar 87 psi	2 bar = 29 psi		4 bar = 58 psi		6 bar = 87 psi		2 bar = 29 psi		4 bar = 58 psi		62 bar = 87psi	
				kg	lbs	kg	lbs	kg	lbs	dm ³	cf	dm ³	cf	dm ³	cf
S 20	10.500	14.500	16.500	72	162	122	275	172	387	130	4.6	230	81	340	12.0
S 25	9.200	12.200	14.000	93	209	157	353	205	461	160	5.6	290	10.2	425	15.0

ELECTRIC EXTERNAL MOTOVIBRATORS - ELEKTRISCHE VIBRATIONSMOTOREN
MOTOVIBRATEURS EXTERNES ELECTRIQUES - MOTOVIBRATORI ELETTRICI
MVE

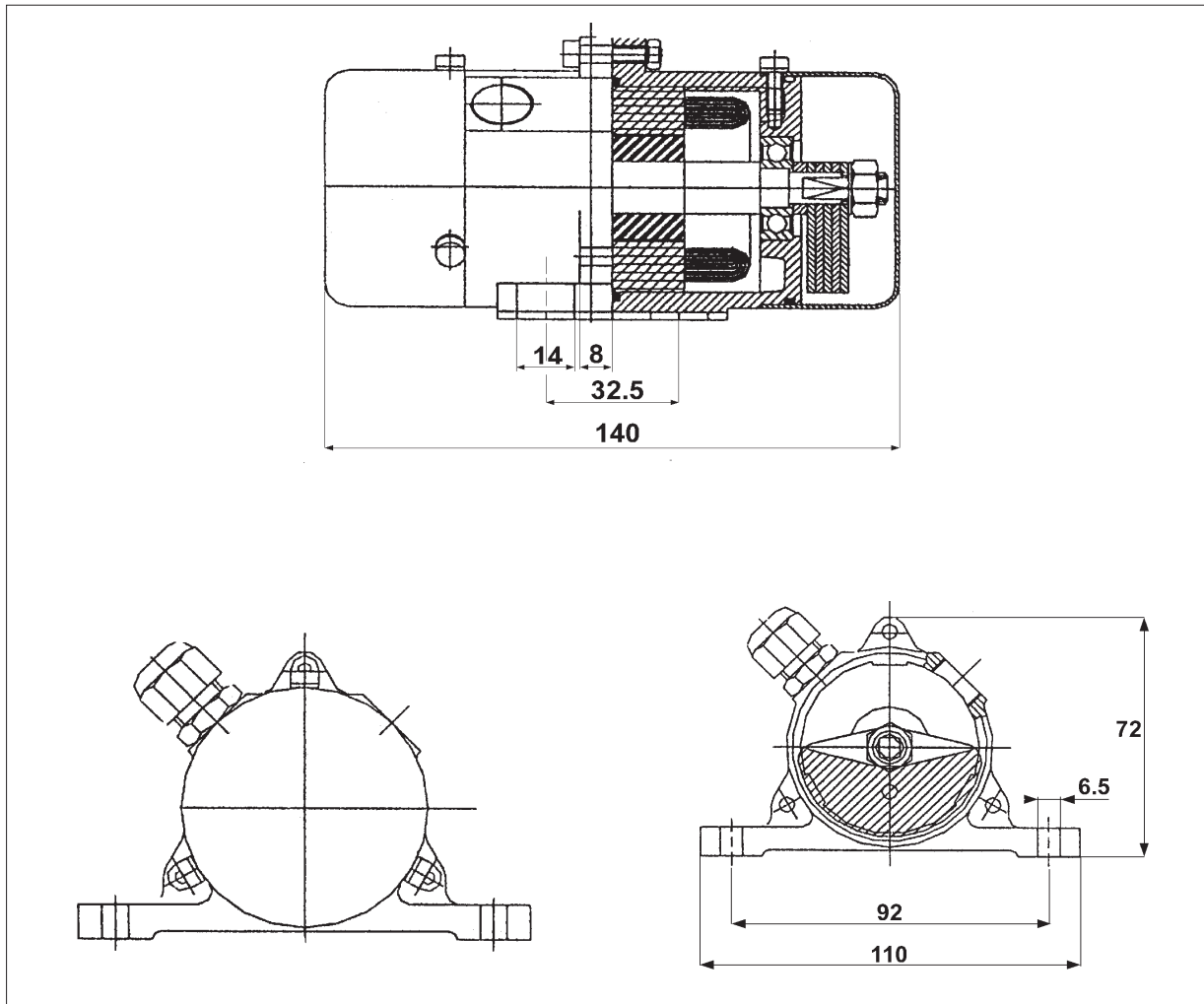

Type	Max. power Max. Leistung Puissance max. Potenza max. W		Max. current Max. Stromaufnahme Courant max. Assorbimento max. A		RPM U/min TPM Giri/min		Centrifugal force Zentrifugalkraft Force centrifuge Forza centrifuga kg		Weight Gewicht Poids Peso
	50 Hz	60 Hz	220 V 50 Hz	115 V 60 Hz	50 Hz	60 Hz	50 Hz	60 Hz	kg
MVE 20	32	36	0.10	0.23	2750	3300	0-22	0-32	1.5

TECNICAL FEATURES

- Adjustable Centrifugal Force
- Protection IP 65
- Insulation Class "F"
- Continuous Duty

TECHNISCHE MERKMALE

- Einstellbare Zentrifugalkraft
- Schutzart IP 65
- Iso-Klasse F
- 100% ED

CARACTERISTIQUES TECHNIQUES

- Force centrifuge réglable
- Protection IP 65
- Classe d'isolation F
- Service continu

CARATTERISTICHE TECNICHE

- Forza centrifuga regolabile
- Protezione IP 65
- Classe d'isolamento F
- Servizio continuo

SPECIAL BLENDING TOOLS - SPEZIAL-HOMOGENISIERWERKZEUGE
OUTILS DE HOMOGENEISATION SPECIAUX - UTENSILI OMOGENEIZZAZIONE SPECIALI

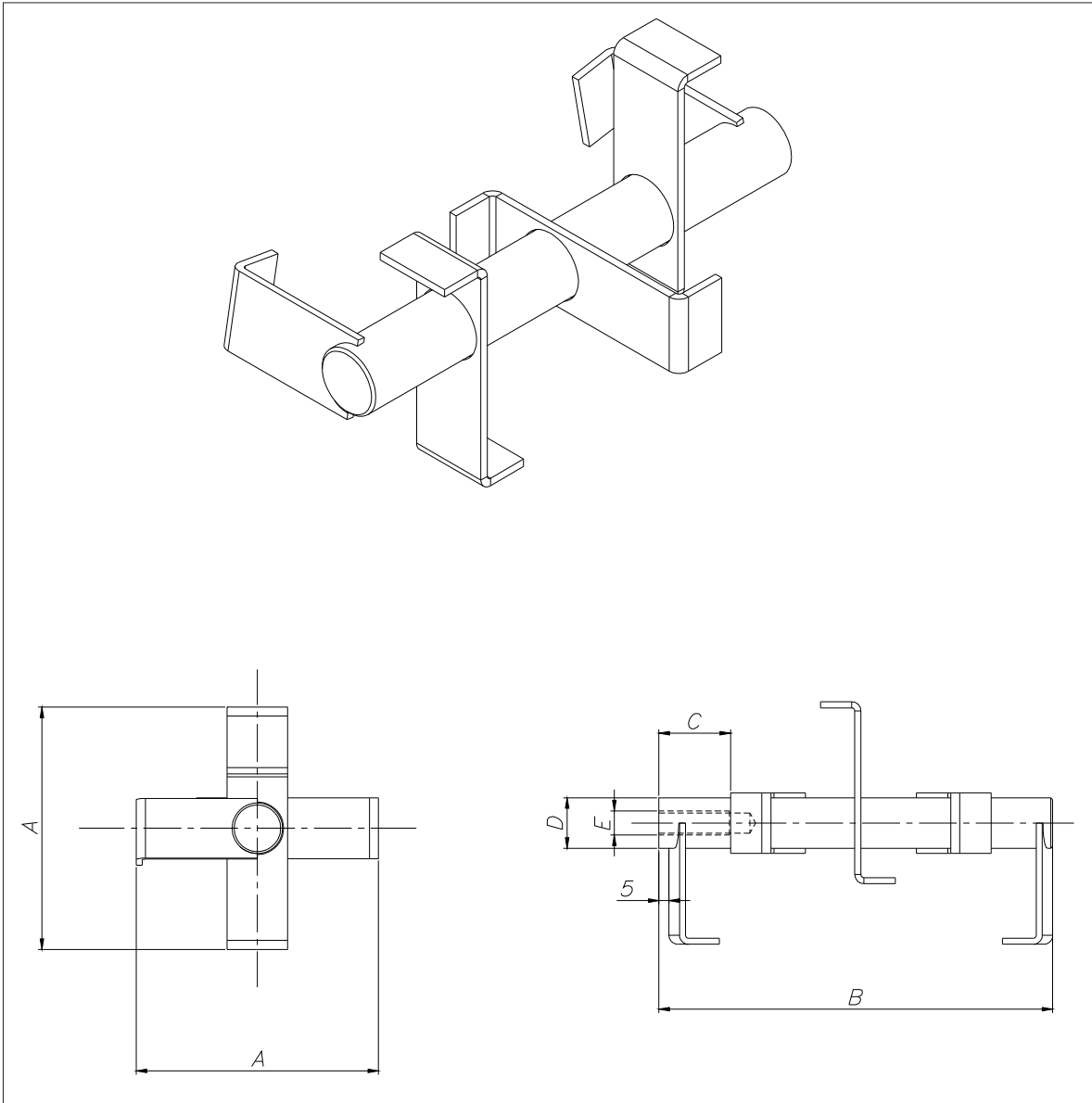
TYPE1

MBF	Code	A	B	D	E	kg
042	UTO 12	130	199	25	M 12	1
073	UTO 13	260	349	35	M 16	3.5
114	UTO 13	260	349	35	M 16	3.5

**STD INSPECTION HATCH FOR AISI 304L MBF TYPE - STD INSPEKTIONSTÜR FÜR MBF IN EDELSTAHL 1.4301
 TRAPPE DE VISITE STD POUR MBF DANS AISI 304L - PORTELLO DI ISPEZIONE STD PER MBF IN AISI 304L**

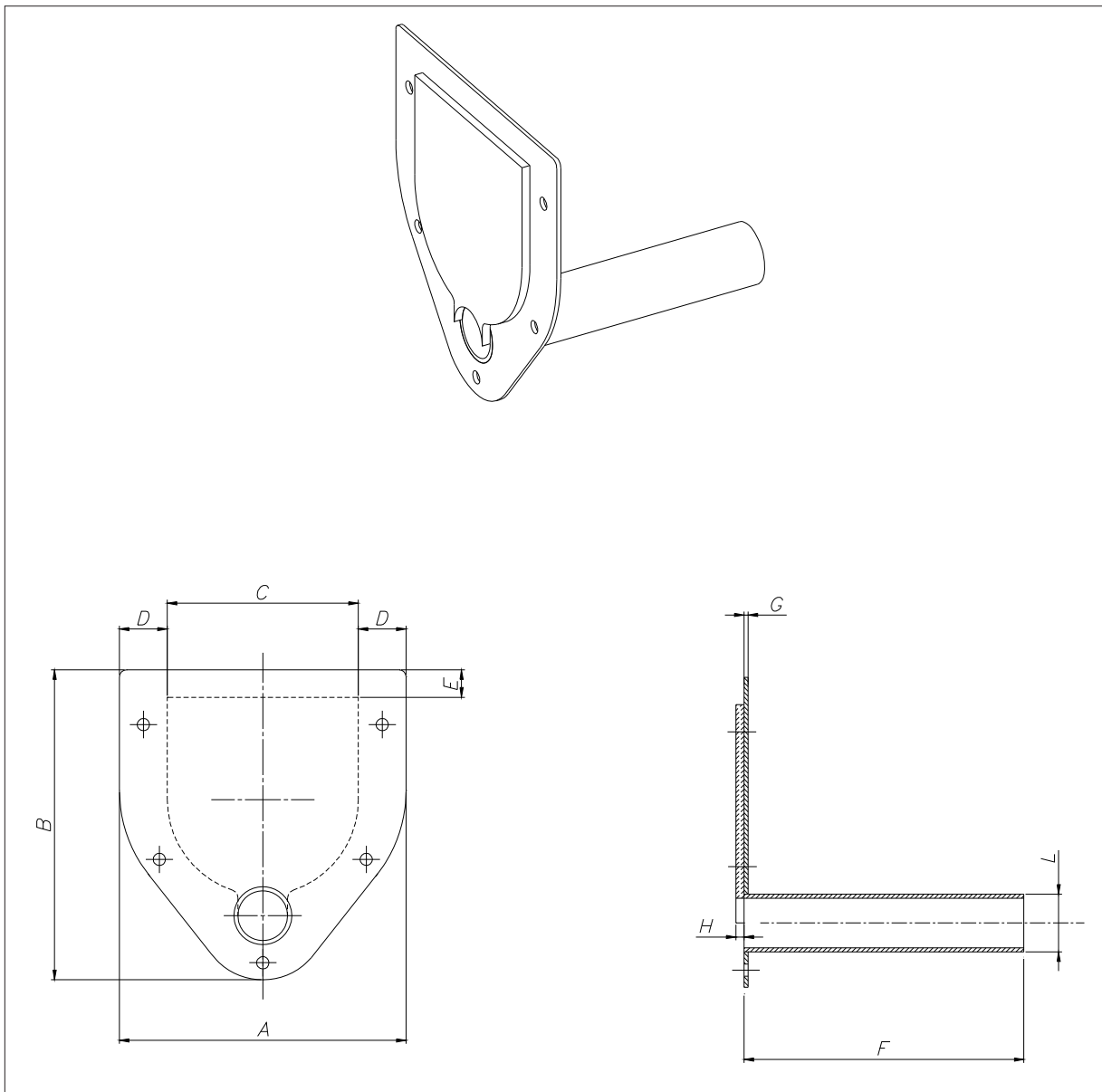

MBF	Code	A	B	C	D	E	F	G	H	Ø L	kg
042	MBPI 2	210	227	140	35	20	205	3	6	42	1.4
073	MBPI 3	345	395	275	35	20	255	3	6	76	5.6
114	MBPI 4	350	431	275	37	20	255	3	6	114	6.3

INSPECTION HATCH FOR AISI 304L MBF TYPE WITH EXTENDED TUBE
INSPEKTIONSTÜR FÜR MBF IN EDELSTAHL 1.4301 MIT LÄNGLICHROHR
TRAPPE DE VISITE POUR MBF DANS AISI 304L AVEC TUBE PROLONGE
PORTELLO DI ISPEZIONE PER MBF IN AISI 304L CON TUBO PROLUNGATO

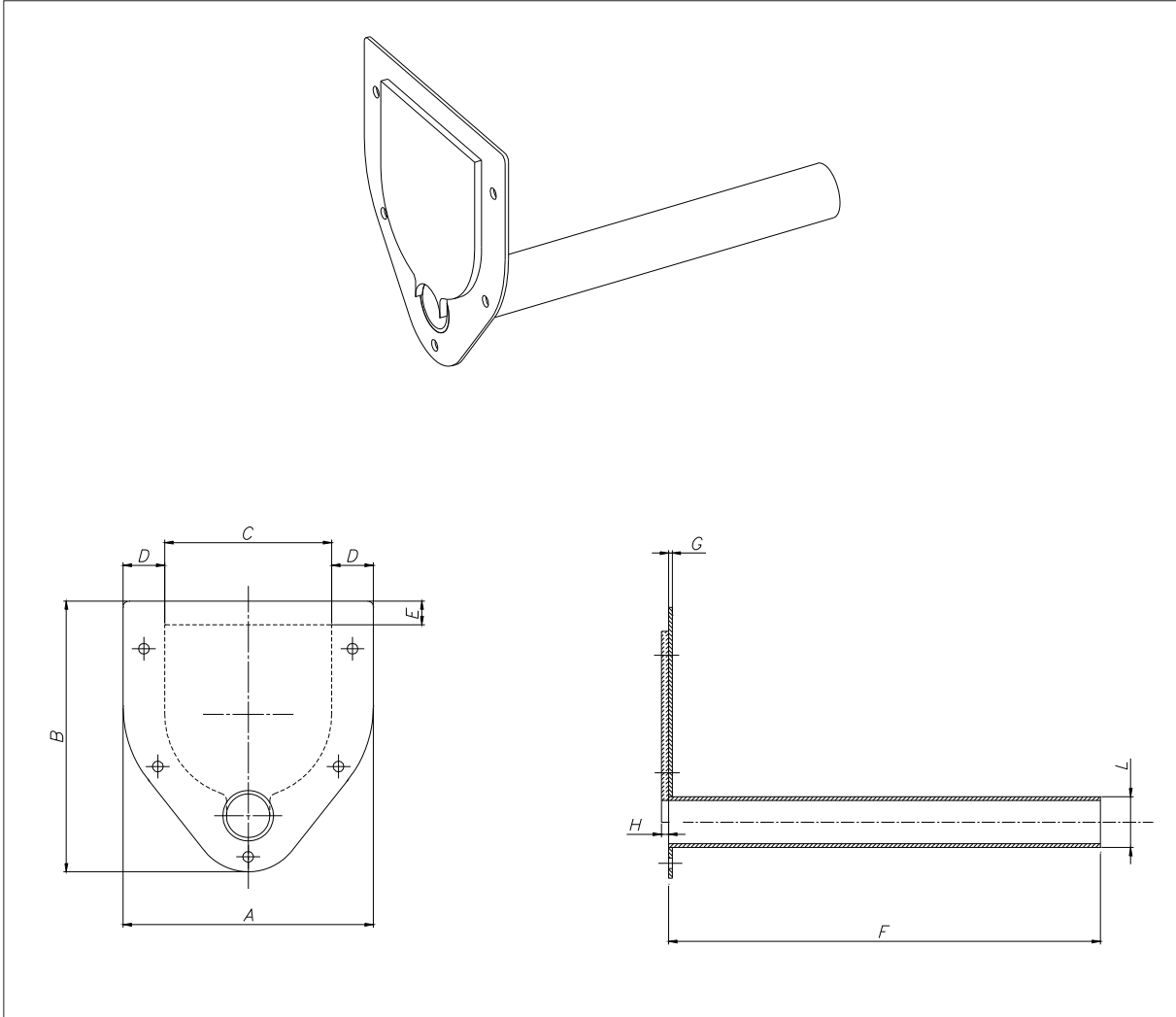

MBF	Code	A	B	C	D	E	F	G	H	Ø L	kg
042	MBPIP 2	210	227	140	35	20	362	3	6	42	1.8
073	MBPIP 3	345	395	275	35	20	505	3	6	76	6.8
114	MBPIP 4	350	431	275	37	20	505	3	6	114	7.4

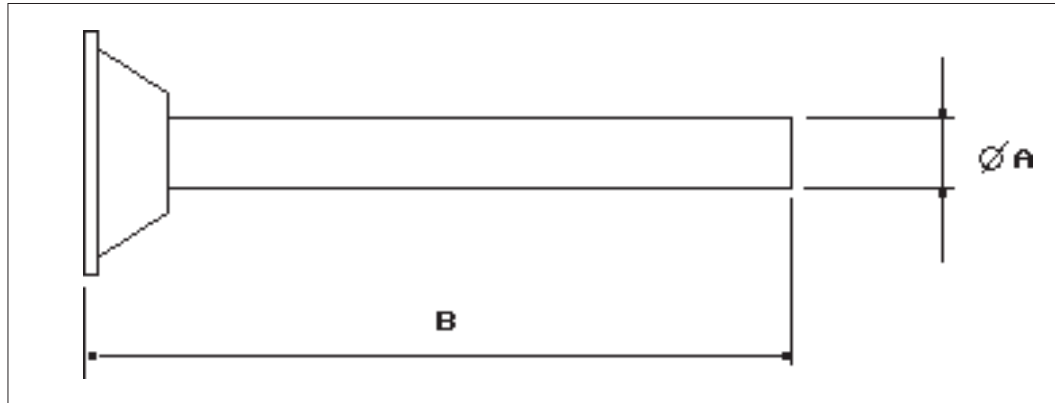
FEEDER PIPE - DOSIERROHR - TUBE DE DOSAGE - SCARICO

STANDARD FEEDER PIPE - STANDARD DOSIERROHR - TUBE DE DOSAGE STANDARD - SCARICO STANDARD				
Code	Suitable for - <i>Passend zu</i> Pour type - <i>Idoneo per</i> MBF	Ø A	B	kg
MBT 2	042	42	200	1.0
MBT 3	073	76	250	2.4
MBT 4	114	114	250	4.0

EXTENDED FEEDER PIPE - VERLÄNGERTES DOSIERROHR - SORTIE RALLONGEE - SCARICO PROLUNGATO				
Code	Suitable for - <i>Passend zu</i> Pour type - <i>Idoneo per</i> MBF	Ø A	B	kg
MBTP 2	042	42	370	1.2
MBTP 3	073	76	500	2.7
MBTP 4	114	114	500	4.4

LINERFEEDER PIPE - DOSIERROHR MIT INNENAUSKLEIDUNG
TUBE DE DOSAGE AVEC REVETEMENT INTERIEUR - SCARICO INTERNAMENTE RIVESTITO

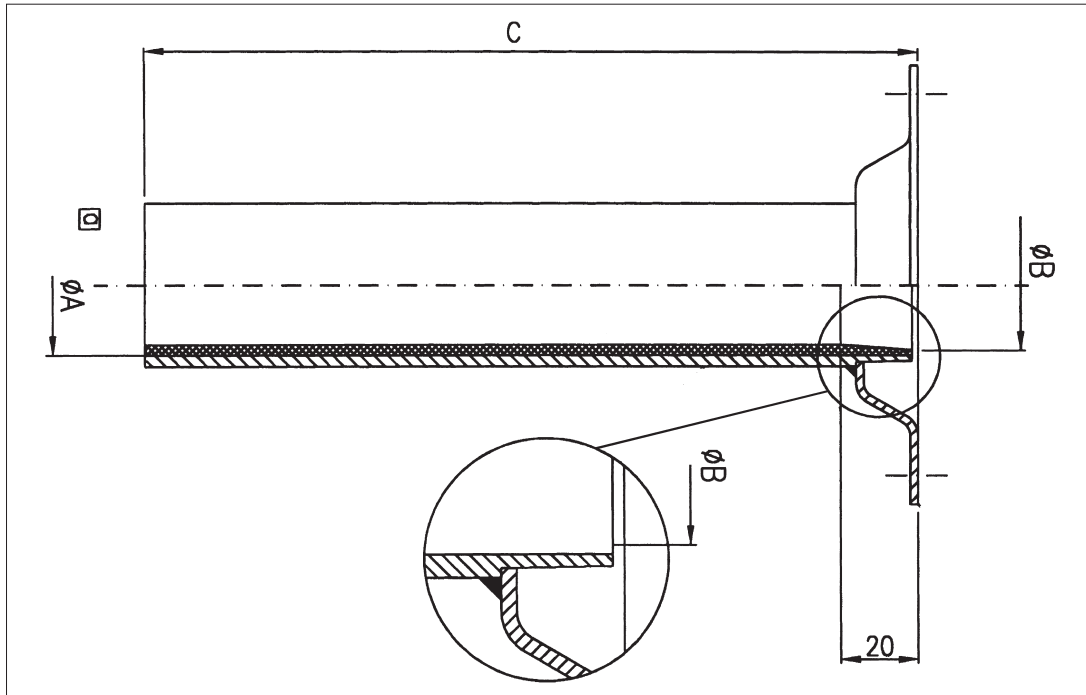

4 SINT[®]ER
 5 SINT[®]AL

STANDARD LINED FEEDER PIPE - STANDARD DOSIERROHR MIT INNENAUSKLEIDUNG TUBE DE DOSAGE AVEC REVETEMENT INTERIEUR - SCARICO STD INTERNAMENTE RIVESTITO					
Code	Suitable for - Passend zu Pour type - Idoneo per MBF	Ø A	Ø B	C	kg
MBTR 2.	042	31	34	200	1.2
MBTR 3.	073	61	63	250	2.7
MBTR 4.	114	101	104	250	4.4

4 SINT[®]ER
 5 SINT[®]AL

EXTENDED LINED FEEDER PIPE - VERLÄNGERTES DOSIERROHR MIT INNENAUSKLEIDUNG TUBE DE DOSAGE RALLONGE AVEC REVETEMENT INTERIEUR - SCARICO PROLUNGATO INTERNAMENTE RIVESTITO					
Code	Suitable for - Passend zu Pour type - Idoneo per MBF	Ø A	Ø B	C	kg
MBTRP 2.	042	31	34	370	1.6
MBTRP 3.	073	61	63	500	3.2
MBTRP 4.	114	101	104	500	5.2

VERTICAL SPOUT - ABLAUFROHR - SORTIE VERTICALE - SCARICO VERTICALE

M D X S V 2 4

4: SINT®ER
 5: SINT®AL

2 = MBF 042
 3 = MBF 073
 4 = MBF 114

Vertical spout
 Ablaufrohr
 Sortie verticale
 Scarico verticale

Micro-batch feeder accessories
 Zubehör Mikrodosierer
 Accessoires microdoseur
 Accessori microdosatore

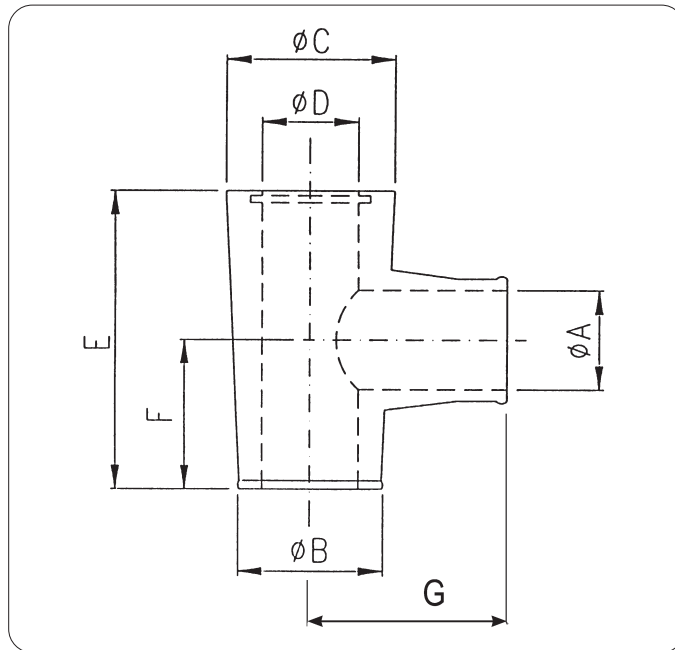

MDXSV	Suitable for - Passend zu Pour type - Idoneo MBF	Ø A	Ø B	Ø C	Ø D	E	F	G	kg
2.	042	42	60	70	50	126	63	81	0.27
3.	073	75	121	130	100	187.5	95	143.5	1.3
4.	114	114	175	190	150	230	115	191	3

4 SINT®ER
 5 SINT®AL

**VERTICAL SPOUT WITH PNEUMATIC CLOSURE - ABLAUFROHR MIT PNEUMATISCHEM VERSCHLUSS
 SORTIE VERTICALE AVEC FERMETEURE PNEUMATIQUE - SCARICO VERTICALE CON CHIUSURA PNEUMATICA**

M D X S C 2 4

4: SINT®ER
 5: SINT®AL

2 = MBF 042
 3 = MBF 073
 4 = MBF 114

vertical spout with pneumatic cover
 Ablaufrohr mit pneumatischemverschluss
 Sortie verticale avec fermeteure pneumatique
 Scarico verticale con chiusura pneumatica

Micro-batch feeder accessories
 Zubehör Mikrodosierer
 Accessoires microdoseur
 Accessori microdosatore

N.B.: Operation P_{max} 4 bar !
N.B.: Betrieb P_{max} 4 bar !
N.B.: P_{max} de travail 4 bar !
N.B.: P_{max} di lavoro 4 bar !

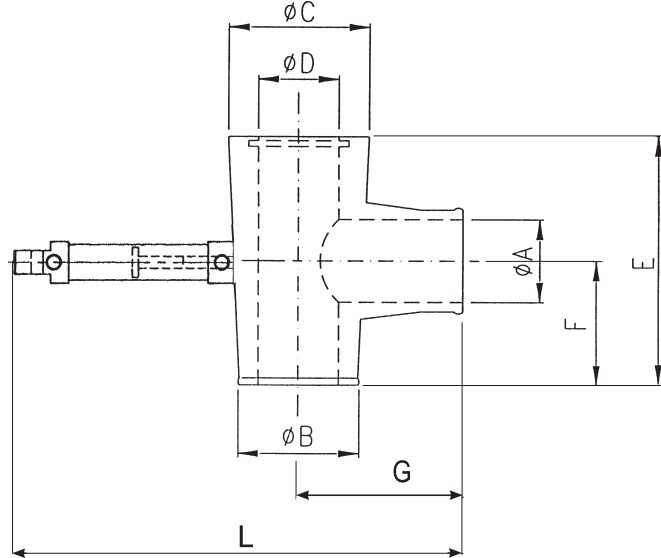

MDXSC	Suitable for - Passend zu Pour type - Idoneo MBF	Ø A	Ø B	Ø C	Ø D	E	F	G	L	kg
2.	042	42	60	70	50	126	63	81	214.5	0.5
3.	073	75	121	130	100	187.5	95	143.5	353.5	2.8
4.	114	114	175	190	150	230	115	191	472	4.5

4 SINT®ER
 5 SINT®AL

Note: Microcylinder ISO 6432 - Anm.: Mikrozyylinder ISO 6432
 Remarque: Micro-cylindre ISO 6432 - Nota: Microcilindro ISO 6432

**MAGNETIC SENSOR KIT FOR MICRO-CYLINDER - MAGNETISCHES SENSORKIT FÜR MIKROZYLINDER
 KIT SENSEUR MEGNETIQUE POUR MICRO-CYLINDRE - KIT SENSORE MAGNETICO RILEVAMENTO PER MICROCILINDRO**

KXM	Suitable for - Passend zu Pour type - Idoneo MBF
16	MDXSC2
20	MDXSC3
25	MDXSC4

AUTOMATIC LUBRICATOR

AUTOMATISCHE SCHMIERVORRICHTUNG

GRAISSEUR AUTOMATIQUE

LUBRIFICATORE AUTOMATICO

**CARTRIDGE GREASE NIPPLE LIT - SCHMIERPATRONENSATZ
 KIT GRAISSEUR CARTOUCHE - KIT INGRASSATORE CARTUCCIA**

M D X I 125

Capacity - Kapazität - Capacité - Capacità

Grease nipple - Schmiernippel - Graisseur - Ingrassatore

Micro-batch feeders accessories - Mikrodosierer zubehör
 Accessoires microdoseurs - Accessori microdosatore

TECHNICAL SPECIFICATIONS	
Capacity	125 ml
Operating period	Adjustable at 1-12 months
Operating temperature	-20°C a + 55°C°
Max. operating pressure	5 bar**
Activation mechanism	Hydrogen gas release battery (H2)
Threading	G 1/4
Recommended storage temperature	+20°C
Storage period	2 years***
Weight	Approx. 190g (including grease)
Appellative	LAGD 125/WA (filled with SKF LGWA 2 grease) LAGD 125/"lubricant"

TECHNISCHE DATEN	
Kapazität	125 ml
Betriebsdauer	Von 1 bis 12 Monate einstellbar
Betriebstemperatur	-20°C bis + 55°C°
Max. Betriebsdruck	5 bar**
Einschaltmechanismus	Wasserstoff freisetzende Batterie (H2)
Gewinde	G 1/4
Empfohlene Lagerhaltungstemperatur	+20°C
Lagerzeit	2 Jahre ***
Gewicht	circa 190 g (Fett inbegriffen)
Bezeichnung	LAGD 125/WA (mit Fett SKF LGWA 2 gefüllt) LAGD 125/"Schmierstoff"

CARACTÉRISTIQUES TECHNIQUES	
Capacité	125 ml
Période de fonctionnement	Réglable de 1 à 12 mois
Température de fonctionnement	-20°C a + 55°C°
Pression max. de fonctionnement	5 bar**
Mécanisme d'activation	Batterie à dégagement de gaz hydrogène (H2)
Filetage	G 1/4
Température conseillée pour le stockage	+20°C
Période de stockage	2 ans***
Poids	Env. 190g (graisse incluse)
Désignation	LAGD 125/WA (avec le plein de graisse SKF LGWA 2 grease) LAGD 125/"lubrifiant"

DATI TECNICI	
Capacità	125 ml
Periodo di funzionamento	Regolabile da 1 a 12 mesi
Temperatura di funzionamento	-20°C a + 55°C°
Pressione max. di funzionamento	5 bar**
Meccanismo di attivazione	Batteria a sviluppo di gas idrogeno (H ₂)
Filettatura	G 1/4
Temperatura consigliata per lo stoccaggio	+20°C
Periodo di stoccaggio	2 anni***
Peso	Circa 190g (grasso incluso)
Appellativo	LAGD 125/WA (riempito con grasso SKF LGWA 2) LAGD 125/"lubrificante"

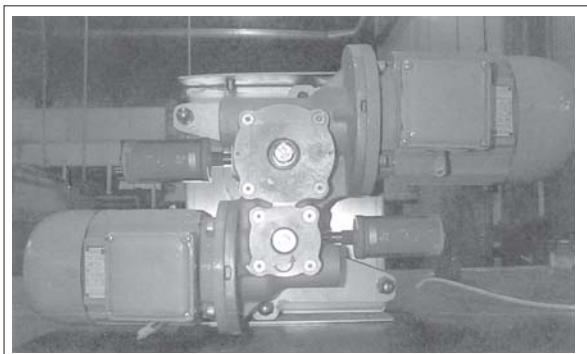
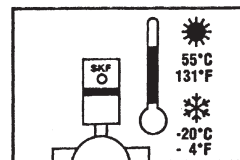
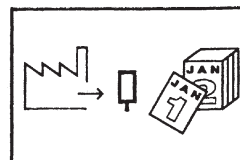

Fig.- Abb. 1
 SKF assembly on Batch feeder - Montage SKF auf Dosierer
 Montage SKF sur doseur - Montaggio SKF su dosatore



Operatin temperature - Betriebstemperatur
 Température de fonctionnement - - Temperatura di funzionamento



Production date - Produktionsdatum
 Date de production - Data di produzione





MATERIAL TO DOSE
PHYSICAL AND CHEMICAL CHARACTERISTICS

DENSITY
 GRANULOMETRY
 FLUIDITY
 ABRASIVITY
 BUILDS UP AND HARDENS
 STATIC ELECTRICITY GENERATOR
 DECOMPOSITION - DAMAGING
 FLAMMABILITY
 PLASTICITY - TENDENCY TO SOFTEN
 DUSTINESS
 AIRATED - FLUIDITY
 EXPLOSIVITY
 VISCOSITY - ADHESIVENESS
 CONTAMINABILITY
 DEGRADABILITY
 PRESENCE OF TOXIC GAS
 HIGH CORROSIVITY
 MEDIUM CORROSIVITY
 HYGROSCOPICITY
 FORMATION OF GRANULES
 INTERLOCKS, AGGLOMERATES
 PRESENCE OF OILS AND GREASE
 TENDENCY TO COMPACT UNDER PRESSURE
 LIGHT AND SOFT
 HIGH TEMPERATURE

REQUEST CAPACITY (dm³/h) (kg/h)

TOLERANCE

LOADING AND HOPPER CAPACITY

MBW MODEL

FEED SCREW AND AGITATOR R

ACCESSORIES

MOTORS V Hz

NOTES

DOSIERMEDIUM
PHYSIKALISCHE UND CHEMISCHE EIGENSCHAFTEN

SCHÜTTGEWICHT
 KÖRNUNG
 FLIESSFÄHIGKEIT
 ABRASIVITÄT
 HÄRTET LEICHT AUS
 LÄDT SICH STATISCHAUF
 VERROTET LEICHT
 LEICHT ENTZÜNDBAR
 PLASTIFIZIERT
 HOHE STAUBENTWICKLUNG
 HOHER LUFTANTEIL
 EXPLOSIV
 VISKOS, STARK HAFTEND
 LEICHT ZU VERUNREINIGEN
 ZERFALLT LEICHT
 ENTWICKELT GIFTIGE GASE ODER RAUCH
 SEHR KORROSIV
 HYGROSKOPISCH
 NEIGT ZUR KORN-ODER KLUMPENBILDUNG
 ÖL-ODER FETTHALTIG
 NEIGT ZUM ANBACKEN
 SEHR LEICHT
 HOHE TEMPERATUR

GEFORDERTE DURCHSATZLEISTUNG (dm³/h) (kg/h)

TOLERANZ % *

ART DER BESCHICKUNG:
 TRICHTERKAPAZITÄT:
 BETRIEBSDAUER : (h/Tag)
 EINSCHALTUNGEN PRO STUNDE:
 WOHIN WIRD DOSIERT ?
 WENN VARIABLE DURCHSATZLEISTUNG GEFORDERT, WARUM ?
 DOSIERER TYPE:

DOSIER-/HOMOGENISIERWERKZEUG R

ZUBEHÖR:

ELEKTROMOTOR (E) V Hz

BEMERKUNGEN :

MATERIAU A DOSER
CARACTERISTIQUES PHYSICO - CHIMIQUES

POIDS SPECIFIQUE
 GRANULOMETRIE
 CORROSION
 ABRASIVITE
 DELATATION ET DURCISEMENT
 ENGENDRE DE L' ELECTRICITE STATIQUE
 DECOMPOSITION - DETERIOSATION
 IMFLAMABLE
 PLASTIQUE
 SOUPLE
 AERE - FLUIDE
 EXPLOSIF
 VISCOSITE
 CONTAMINABLE
 DEGRADABLE
 CREATION DE GAZ TOXIDE ET DE FUME NUISIBLE
 HAUTE CORROSION
 MOYEN CORROSION
 HYGROSCOPIQUE
 FORMATION DE GRANULE
 PRESENTE HUILE ET GRAISSE
 TASSEMENT SOUS PRESSION
 TRES LEGER
 TEMPERATURE ELEVEE

DEBIT DEMANDE (dm³/h) (kg/h)

TOLERANCE

SYSTEME DE CHARGEMENT ET CAPACITE DE LA TREMIE

MICRODOSEUR TYPE

VIS DOSAGE ET HOMOGENEISATION R

ACCESSOIRES

MOTEURS V Hz

NOTES

MATERIALE DA DOSARE
CARATTERISTICHE FISICO CHIMICHE

PESO SPECIFICO
 GRANULOMETRIA
 SCORREVOLEZZA
 ABRASIVITA'
 ACCRESCIMENTO E INDURIMENTO
 GENERA ELETTRICITA' STATICA
 DECOMPOSIZIONE - DETERIORAMENTO
 INFIAMMABILITA'
 PLASTICITA' - TENDENZA ALL'AMMORBIDIMENTO
 POLVEROSITA'
 AERAZIONE - FLUIDITA'
 ESPLOSIVITA'
 VISCOSITA' E ADESIONE
 CONTABILITA'
 DEGRADABILITA'
 CREAZIONE DI GAS TOSSICO DI FUMO NOCIVO
 ALTA CORROSIVITA'
 MEDIA CORROSIVITA'
 IGROSCOPICITA'
 FORMAZIONE DI GRANULI, INTRECCIAMENTI, E AGGLOMERATI
 PRESENZA DI OLII E GRASSI
 IMPACCAMENTO SOTTO PRESSIONE
 MOLTO LEGGERO E SOFFICE
 TEMPERATURA ELEVATA

PORTATA RICHIESTA (dm³/h) (kg/h)

TOLLERANZA

SISTEMA DI CARICO E CAPACITA' TRAMOGGIA

MICRODOSATORE TIPO

UTENSILE DOSAGGIO E OMOG. R

ACCESSORI

MOTORI V Hz

NOTE

N.B. Rights reserved to modify technical specifications

N.B. Angaben ohne Gewähr. Änderungen können ohne Vorankündigung vorgenommen werden.

N.B. Toutes données portées dans le présent catalogue n'engagent pas le fabricant. Elles peuvent être modifiées à tout moment.

N.B. Tutti i dati riportati nel presente catalogo non sono impegnativi e possono subire variazioni in qualsiasi momento.



WAM®

WAM S.p.A.
Via Cavour, 338
I - 41030 Ponte Motta
Cavezzo (MO) - ITALY

 +39 / 0535 / 618111
fax +39 / 0535 / 618226
e-mail info@wamgroup.it
internet www.wamgroup.com
videoconference + 39 / 0535 / 49032